

JVC

SERVICE MANUAL

MODEL
A-X3

STEREO INTEGRATED AMPLIFIER



No. 2508
Nov. 1979

Contents

	Pages
1. Specifications	1
2. Removal Procedures of Top Cover and Front Panel	2
3. Main Parts Location	2
4. Exploded Views and Part Numbers	
4-(1) Front Panel	3
4-(2) Rear Panel	3
4-(3) Chassis Base Ass'y	4
5. Block Diagram	5
6. New Technology	
6-(1) New Development of IC in Super A Circuit	6
6-(2) DC Servo Type Equalizer Circuit with EL FET	6
7. Power Amplifier Adjustment Procedures	
7-(1) Center Voltage	7
7-(2) Idling Current	7
8. Printed Circuit Board Ass'y and Parts List	
8-(1) TDS-5 LED Power Supply	8
8-(2) TXX-215 Power Amp., Power Supply and Speakers	8
8-(3) TXX-216 Equalizer Amp. and Source Selector	11
8-(4) TPS-234 AC Socket	12
8-(5) TPS-255 AC Fuse	12
8-(6) TAP-281 Driver Amp.	14
9. Packing Materials and Part Numbers	16
10. Accessories List	16
11. A-X3 Schematic Diagram	17
12. Parts List with Specified Numbers for Designated Areas	19

Warning: When replacing the parts marked with \triangle , be sure to use the designated parts to ensure safety.

1. Specifications

Overall Specifications

Output Power (TUNER, AUX, TAPE → SP. OUT)	: 55 watts per channel min. RMS (both channels driven, into 8 Ω from 20 Hz to 20 kHz with no more than 0.005% THD) 57 watts per channel min. RMS (both channels driven, into 8 Ω at 1 kHz)
Total Harmonic Distortion (TUNER, AUX, TAPE → SP. OUT)	: 0.005% at rated output, from 20 Hz to 20 kHz, 8 Ω 0.001% at rated output 1 kHz, 8 Ω (Measured by HP Audio Analyzer System) 0.02% at rated output, from 20 Hz to 50 kHz, 8 Ω
Intermodulation Distortion (TUNER, AUX, TAPE → SP. OUT)	: 0.004% at rated output, 8 Ω
Power Band Width (TUNER, AUX, TAPE → SP. OUT)	: 5 Hz – 60 kHz (IHF, both chan- nels driven, 8 Ω , 0.02% THD)
Frequency Response (TUNER, AUX, TAPE → SP. OUT)	: DC – 100 kHz $^{+0}_{-3}$ dB
Damping Factor	: 75 (1 kHz, 8 Ω)

Input Sensitivity/Impedance

Phono (MM)	: 2.5 mV/47 k Ω
Phono (MC)	: 200 μ V/100 Ω
TUNER, AUX, TAPE	: 150 mV/47 k Ω
Signal-to-Noise Ratio	
Phono (MM)	: 84 dB (IHF, A net, short circuit) 83 dB (new IHF)
Phono (MC)	: 67 dB (IHF, A net, short circuit) 76 dB (new IHF)
TUNER, AUX, TAPE	: 109 dB (IHF, A net, short cir- cuit), 83 dB (new IHF)

Tone Controls

BASS	: \pm 8 dB (100 Hz)
TREBLE	: \pm 8 dB (10 kHz)

Muting

: -20 dB

Phono Equalizer Section (Phono → REC. OUT)

Phono Overload	
Phono (MM)	: 220 mV at 1 kHz, 0.005% THD
Phono (MC)	: 15 mV at 1 kHz, 0.005% THD

RIAA Phono Equalization

(MM)	: \pm 0.3 dB (20 Hz – 20 kHz)
(MC)	: \pm 0.5 dB (30 Hz – 20 kHz)

EQ Subsonic Filter

: -6 dB/Oct. (18 Hz)

Total Harmonic Distortion

Phono (MM)	: 0.005% at 10 V output, 20 Hz – 20 kHz
Phono (MC)	: 0.02% at 10 V output, 30 Hz – 20 kHz

Rec. Output/Impedance

: 150 mV/800 Ω

Power Specifications

: See page 19.

Dimensions & Weight

	Dimensions			Weight	
	Height	Width	Depth	Net	Gross
U.S.A. & Canada	12.1 cm (4-3/4")	47.4 cm (18-5/8")	34.5 cm (13-5/8")	8.3 kg (18.3 lbs)	9.5 kg (20.9 lbs)
All Other Areas	12.1 cm (4-3/4")	45.0 cm (17-3/4")	34.5 cm (13-5/8")	8.3 kg (18.3 lbs)	9.5 kg (20.9 lbs)

2. Removal Procedures of Top Cover and Front Panel

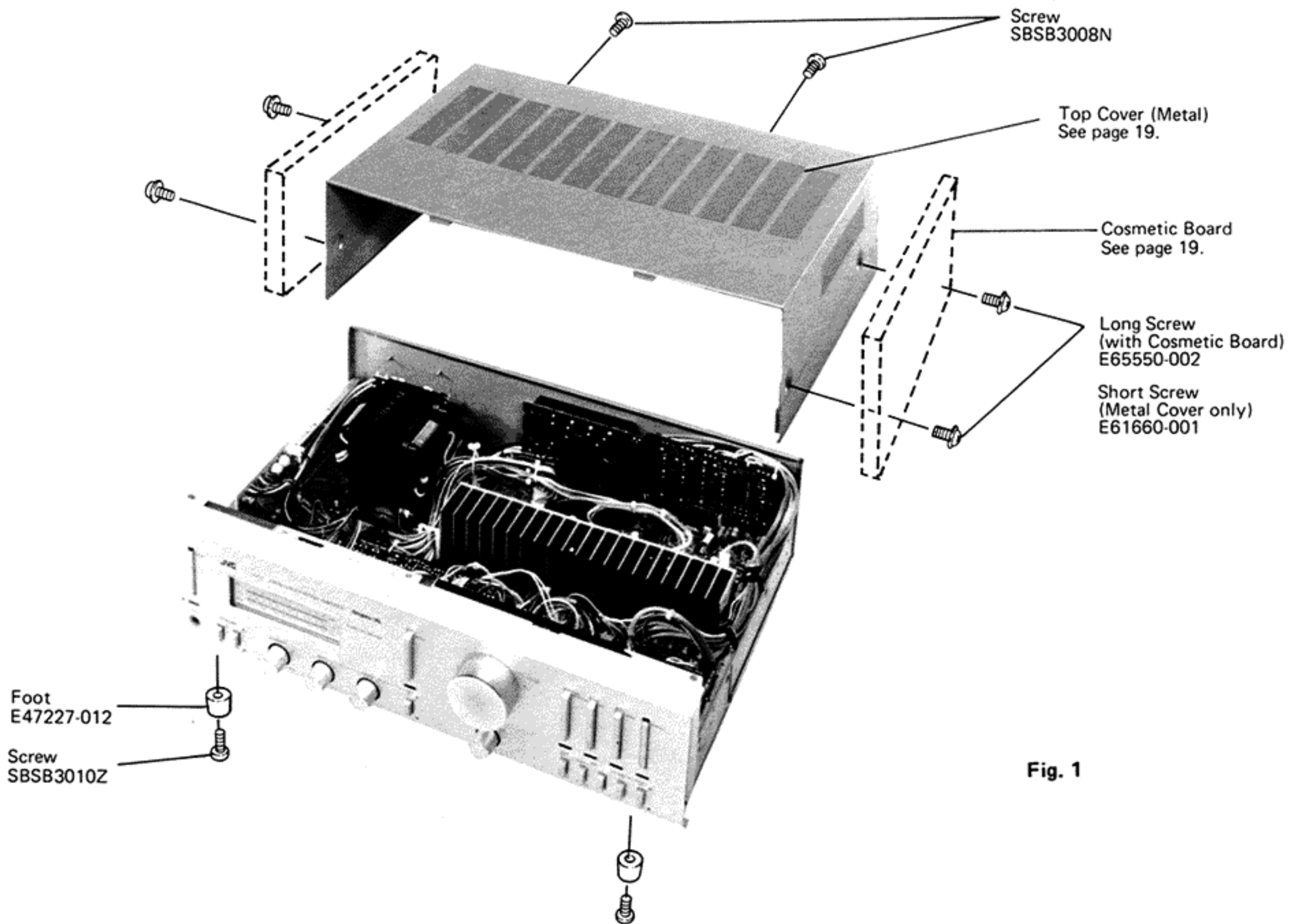

Fig. 1

3. Main Parts Location

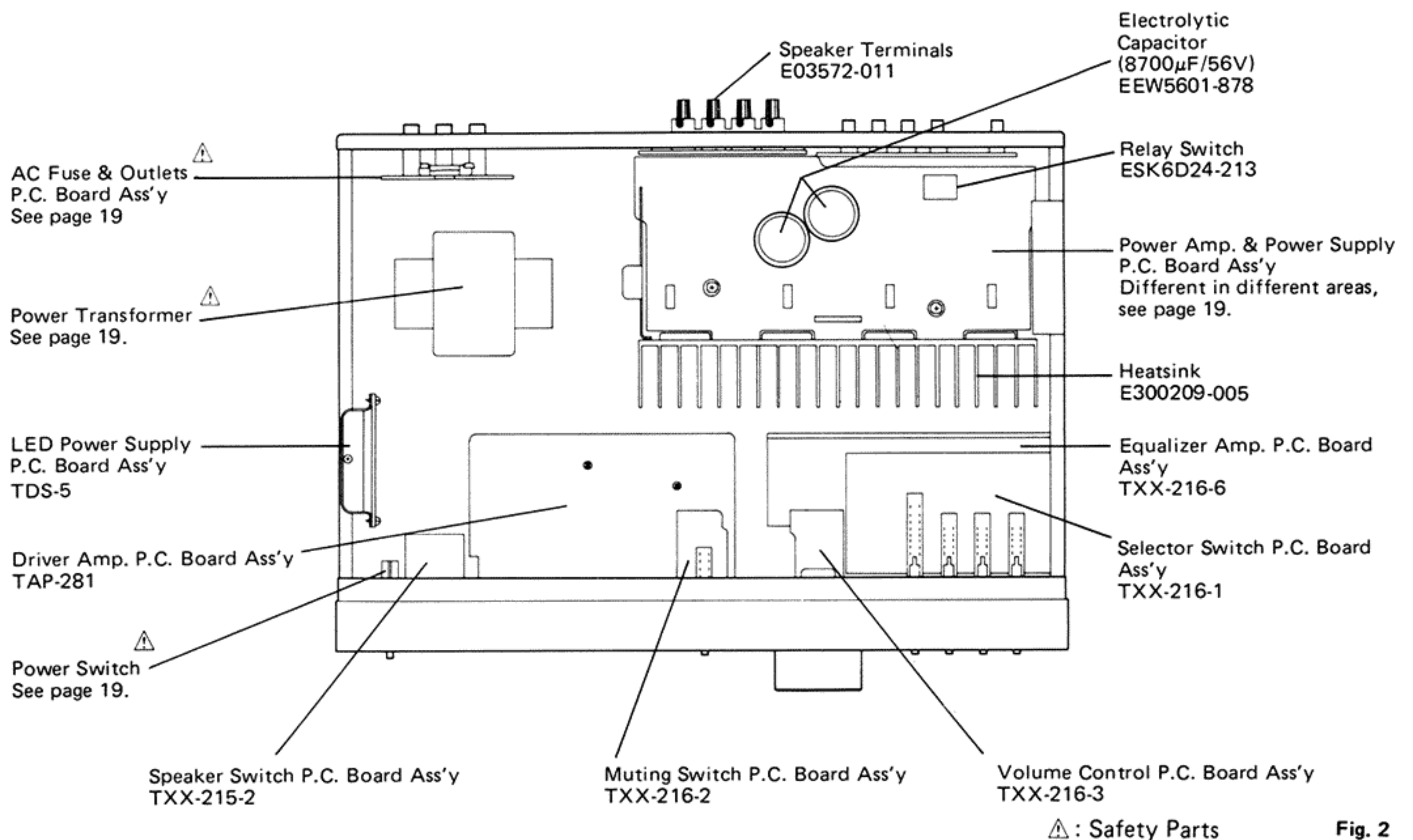

Fig. 2

4. Exploded Views and Part Numbers

4-(1) Front Panel

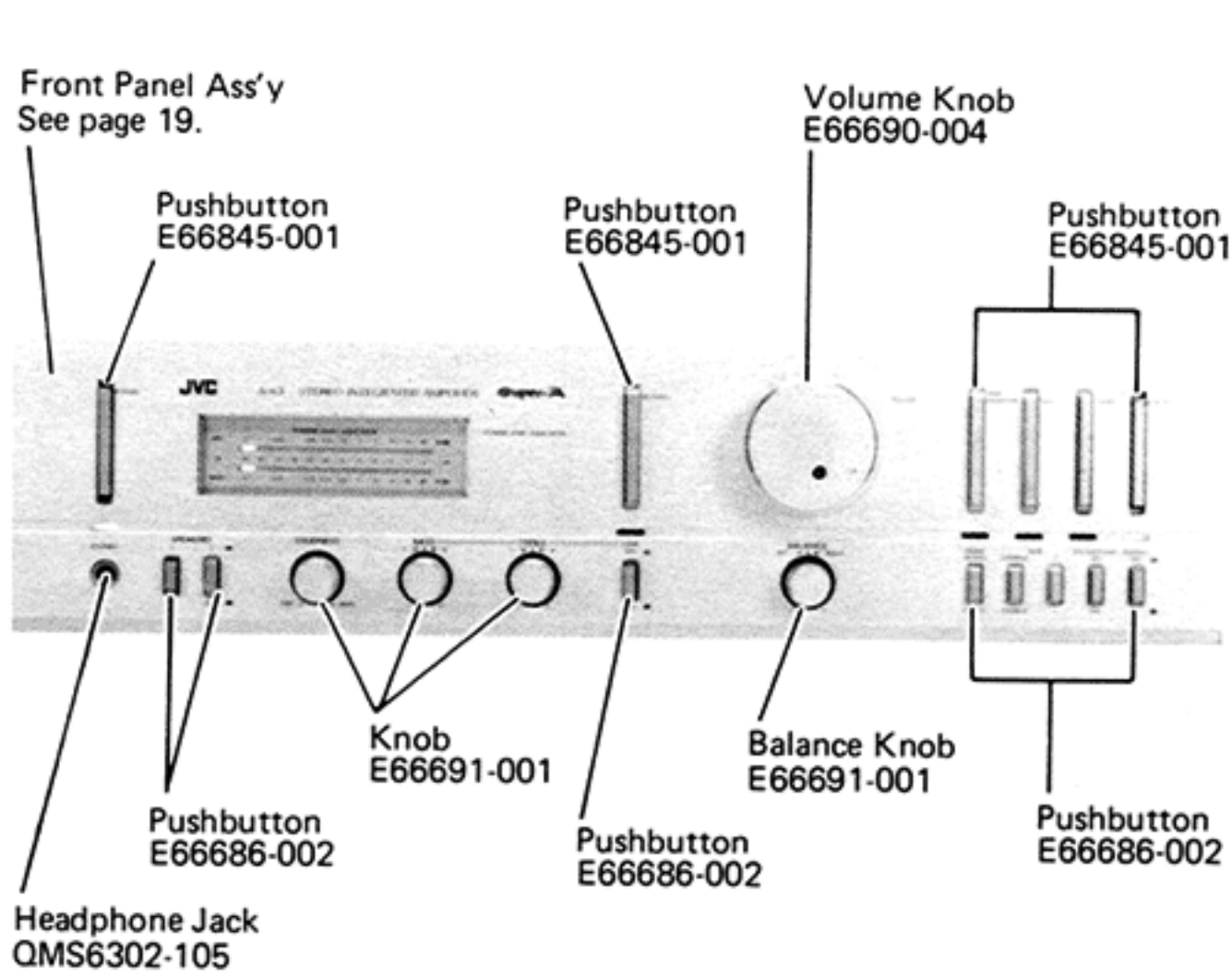

Fig. 3

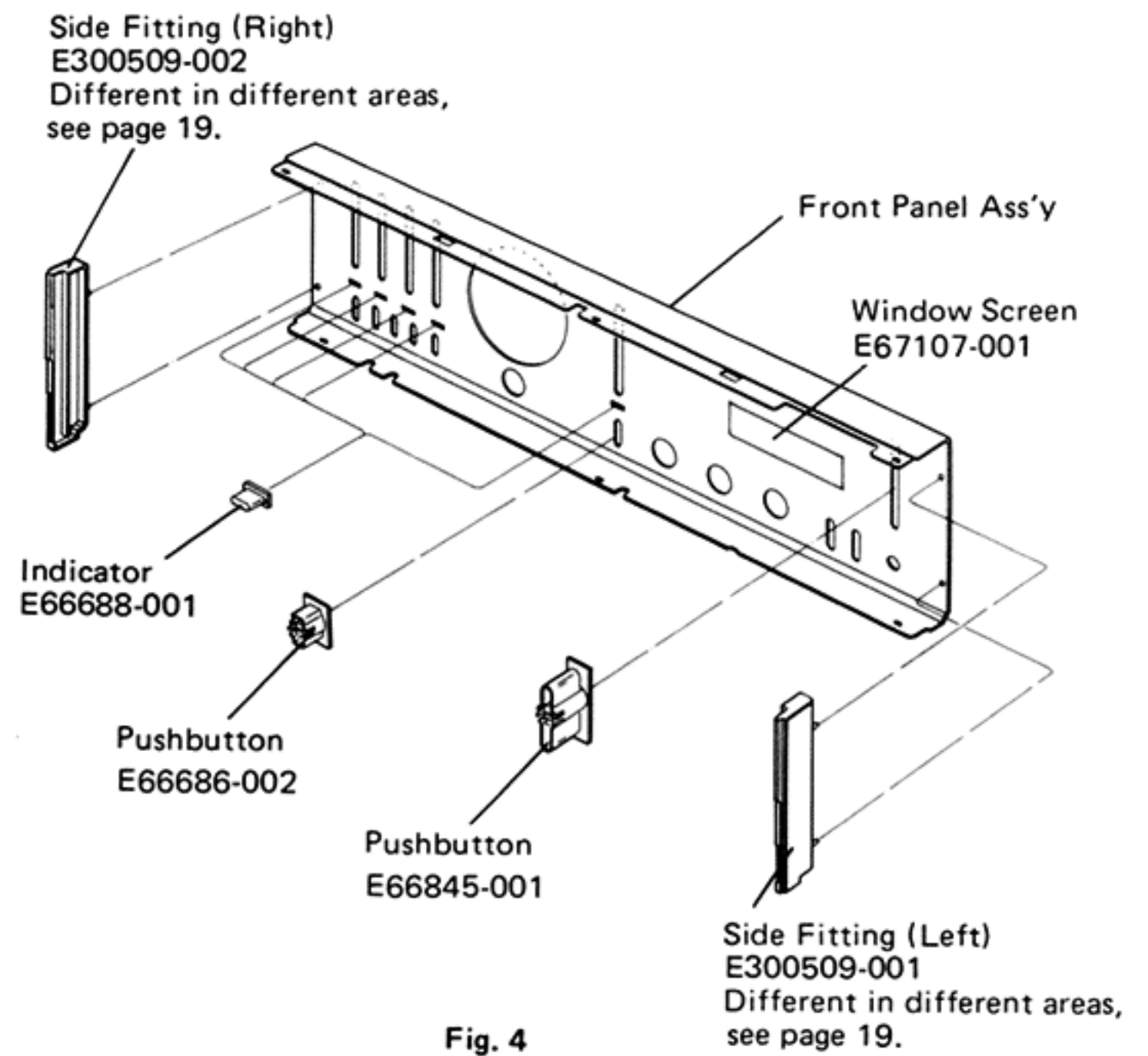

Fig. 4

4-(2) Rear Panel

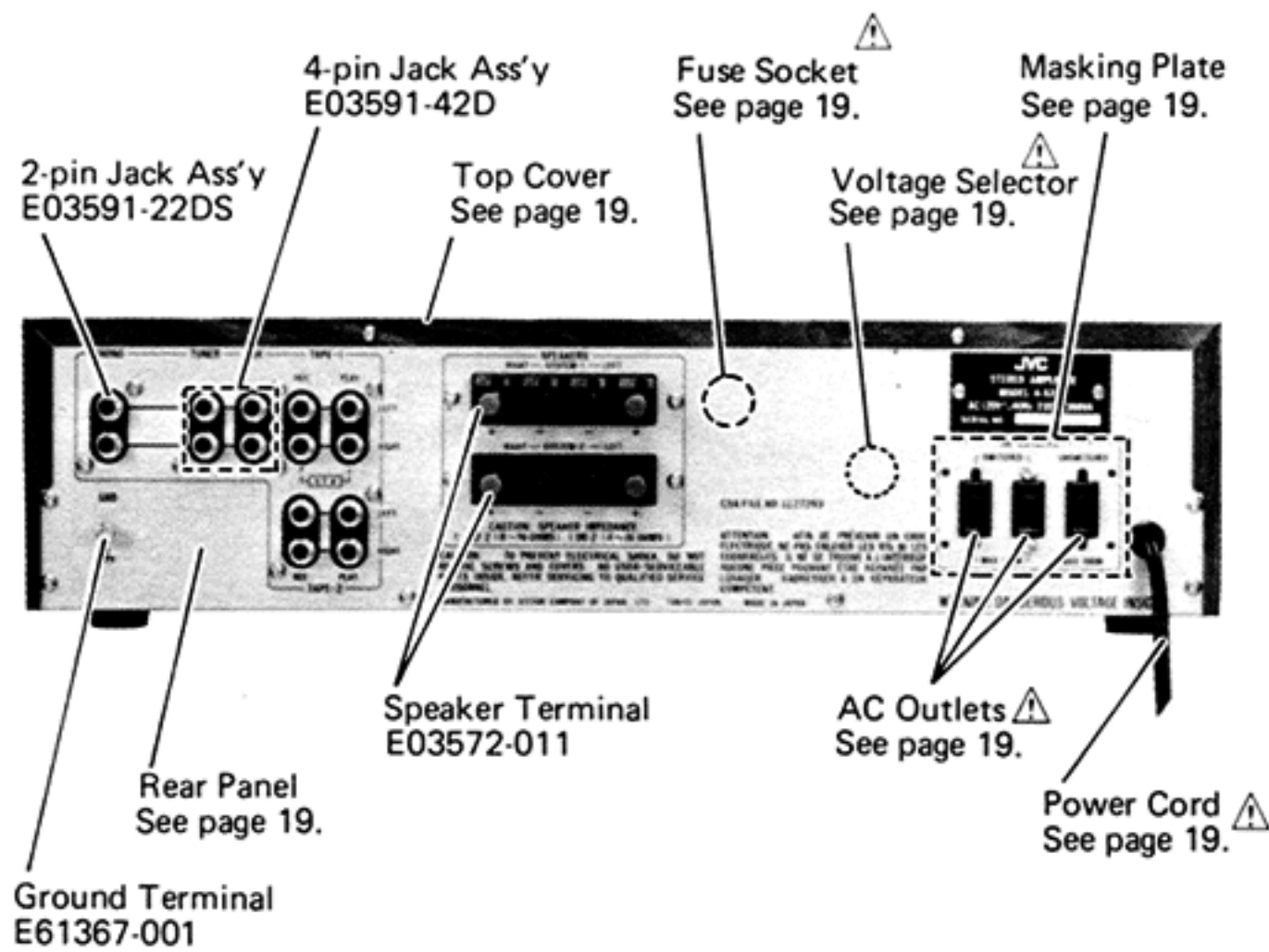

Fig. 5

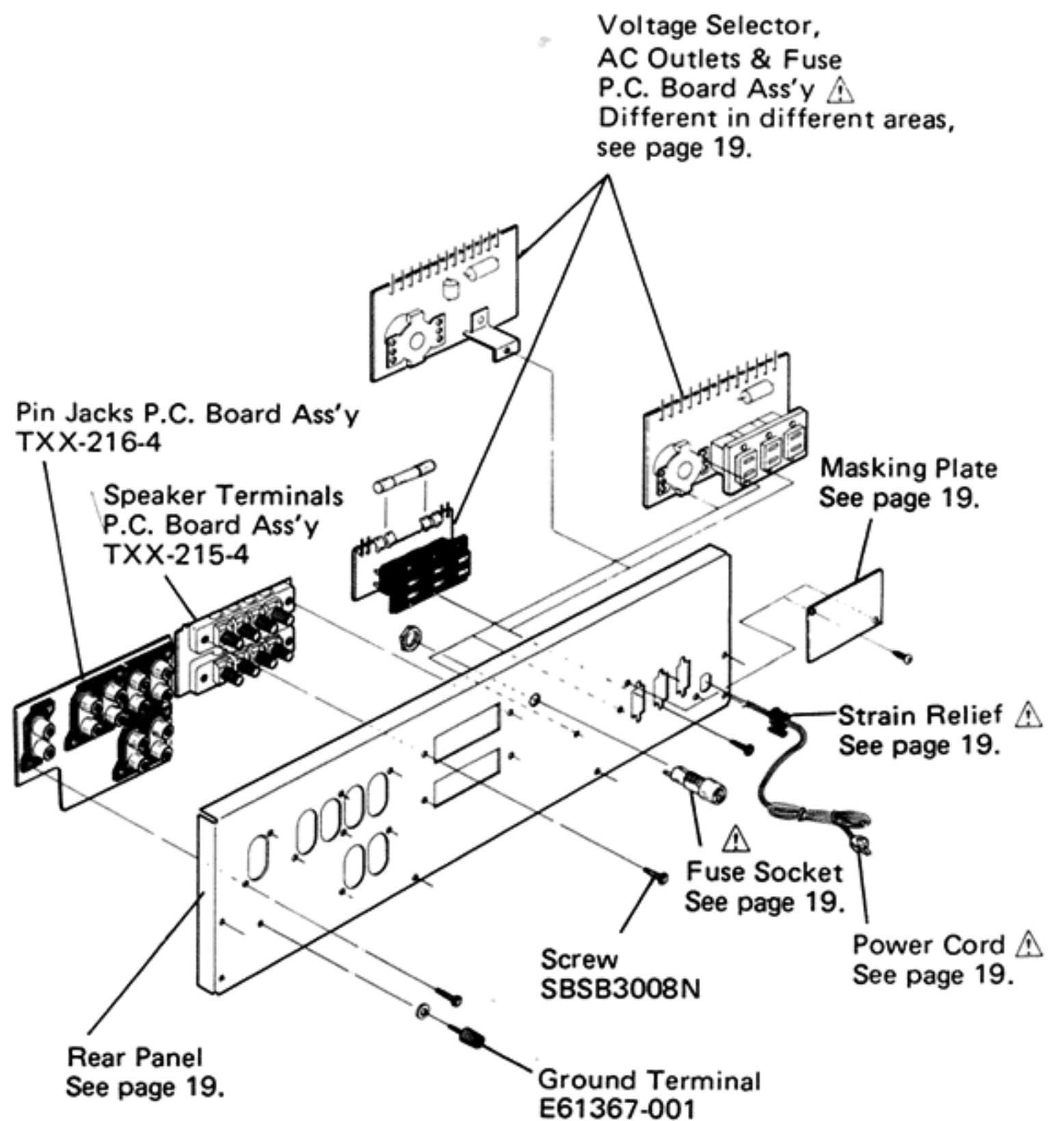

Fig. 6

△ : Safety Parts

4-(3) Chassis Base Ass'y

Replacement of the Power Transistors

Remove the clips of X401 and X402 transistors and unsolder the 4 power transistors X355 - X358 to separate the circuit board from the heatsink and then, replace the power transistors.

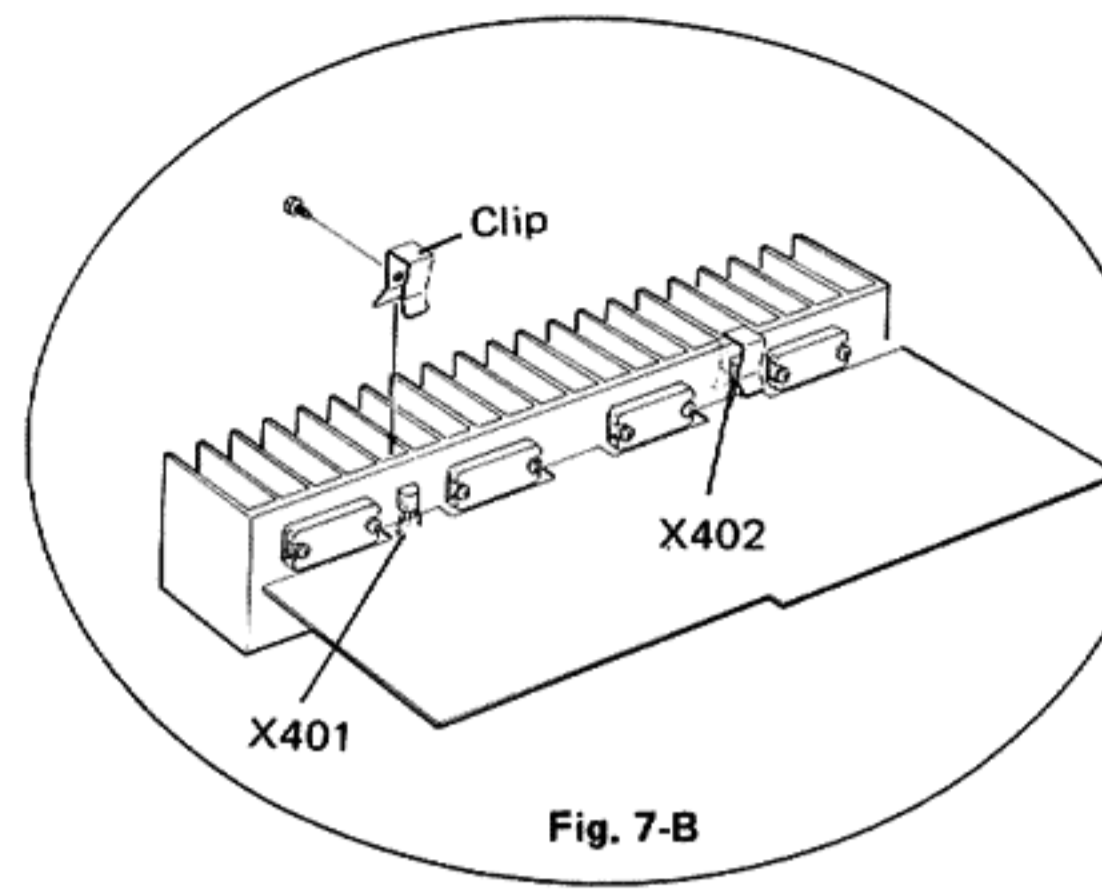

Power Transformer ⚠
Different in different areas,
see page 19

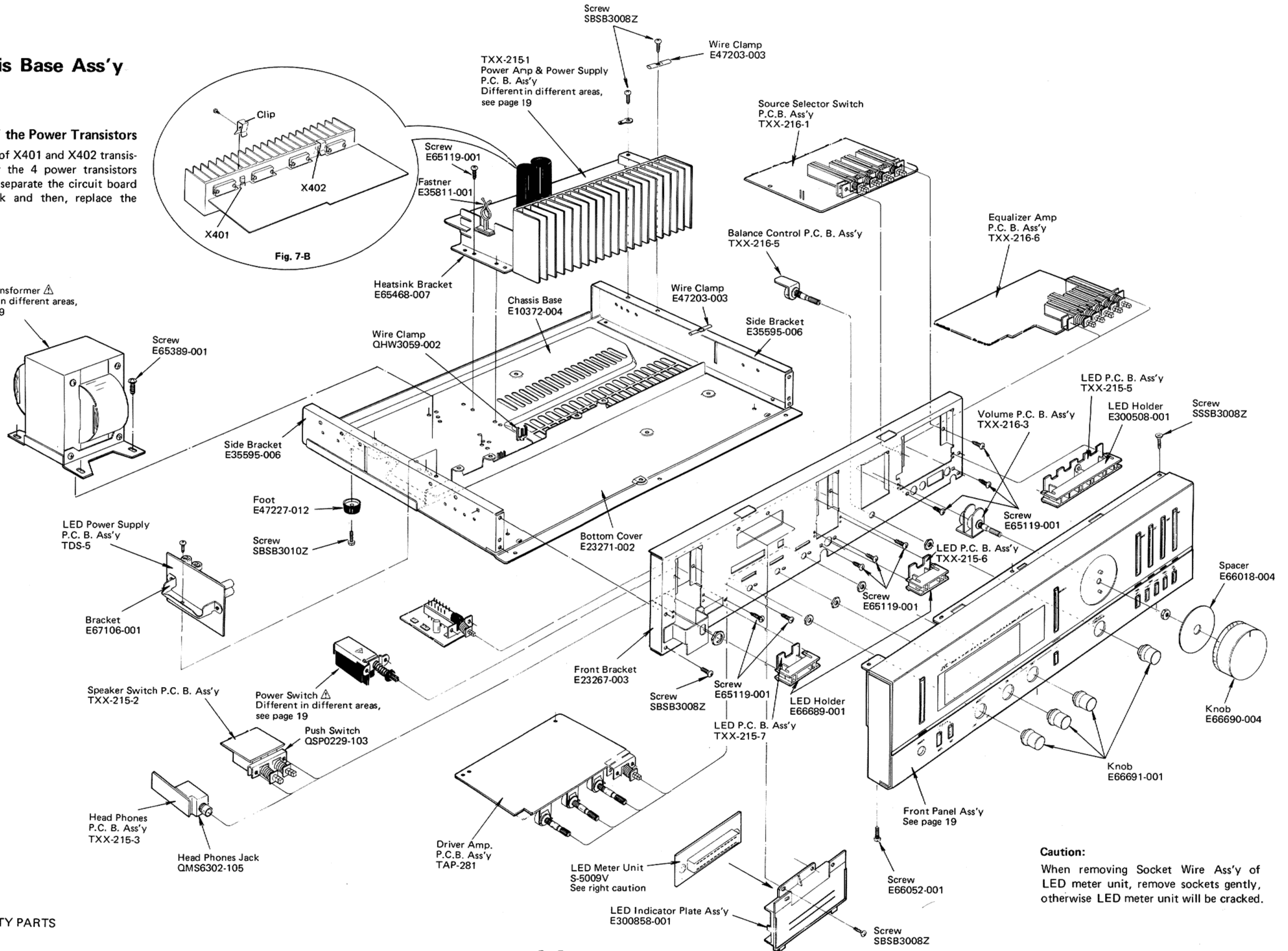

NOTE: ⚠ SAFETY PARTS

Caution:
When removing Socket Wire Ass'y of LED meter unit, remove sockets gently, otherwise LED meter unit will be cracked.

Fig. 7

5. Block Diagram

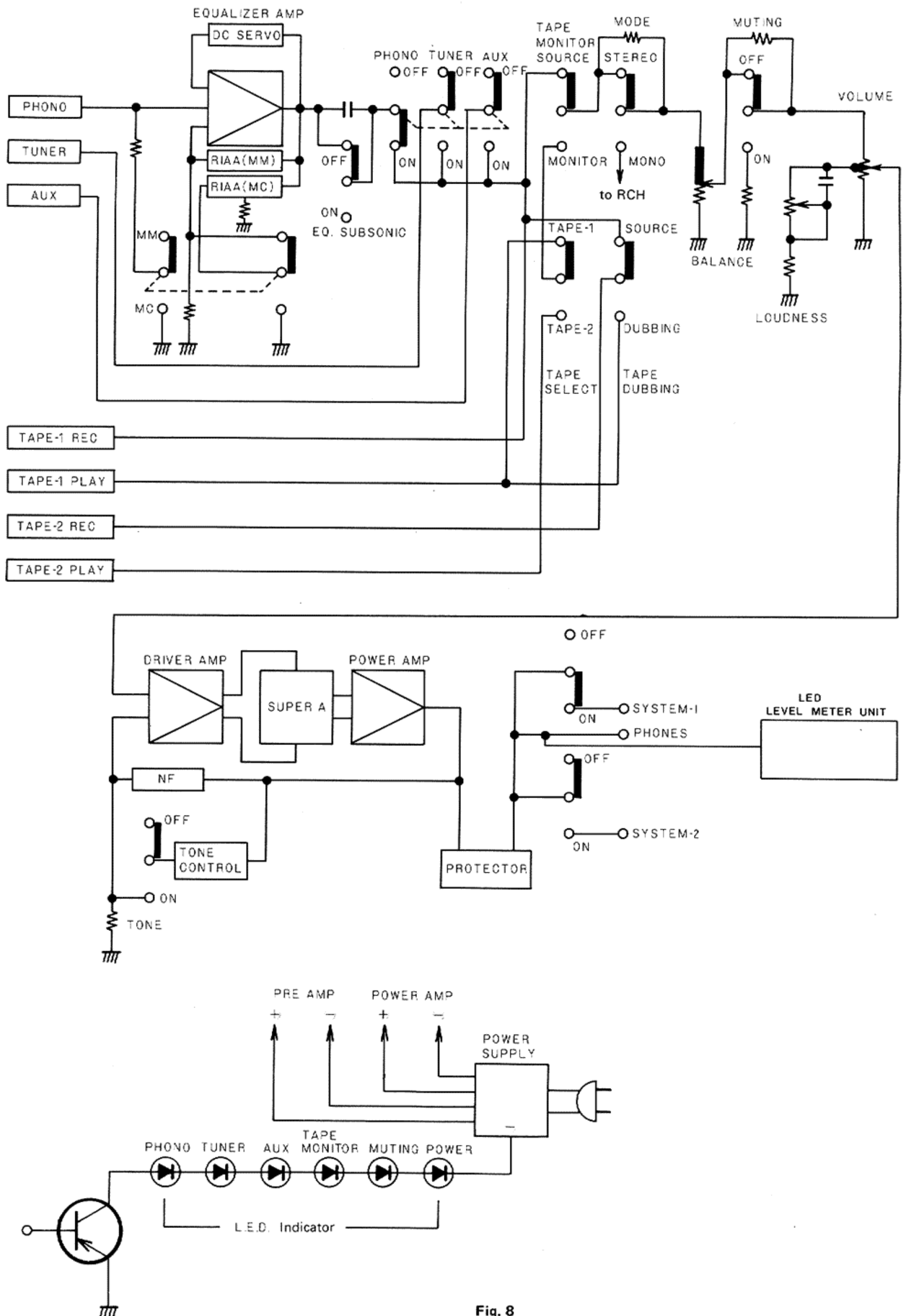

Fig. 8

6. New Technology

6-(1) New Development of IC in Super A Circuit

A newly developed IC has been employed in the heart of the super A bias circuit, thereby simplifying the circuit and improving its performance and reliability. Since the circuit

operation remains entirely the same as the conventional circuit, please refer to page 7 "Power Amplifying Section of Super A System" of the A-X5 service manual (No. 2479).

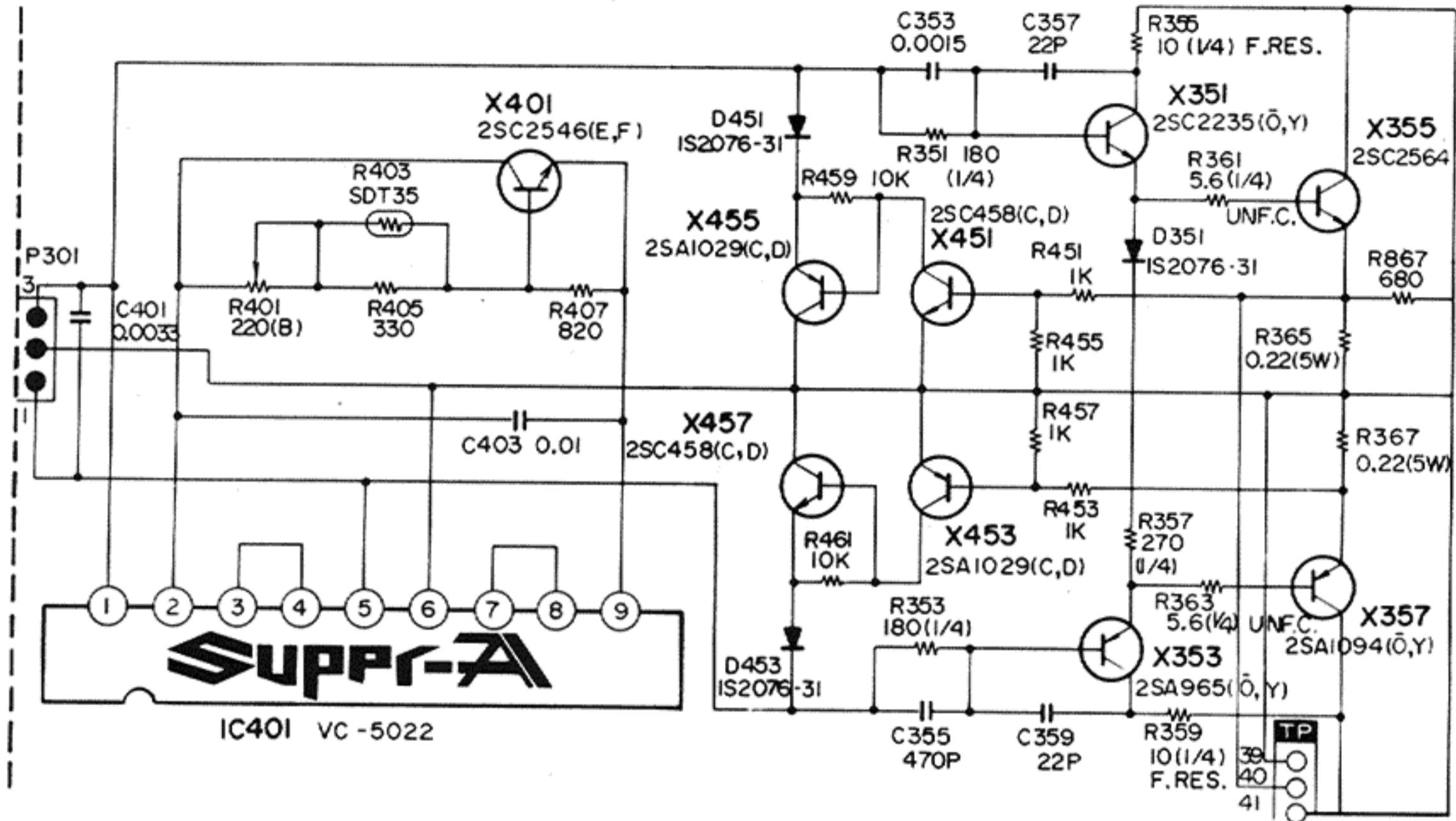

Fig. 9

6-(2) DC Servo Type Equalizer Circuit with EL FET

In order to achieve a 2-stage amplifier with simple circuit design, an EL-FET (2SK240) which was developed for the JVC EQ-7070 stereo phono equalizer is employed in the A-X3 providing a high performance DC Servo Equalizer circuit compatible with the both MM and MC cartridges.

1. Circuit Design

In addition to the DC servo circuit, a 2-stage differential amplifier FET and a high S/N pre-amplifier IC are used to control the offset level to 0V.

2. High S/N design

An EL FET is used as the first stage to form an ICL circuit and to make a high S/N ratio possible.

3. DC Servo Circuit

Increased noise at a ultra low frequencies or offset point level deviation result if the equalizer circuit is designed as a DC amplifier because of the extremely high gain from ultra low frequencies to DC.

The A-X3 incorporating a MC cartridge amplifier eliminates the problem with its DC servo circuit.

The DC servo circuit operates to amplify the signals with the DC servo control circuit consisting of X703 and X705, acting as a low-pass filter circuit, it prevents noise at ultra low frequencies and offset point level deviation by controlling the voltage at pin no. 7 of IC701.

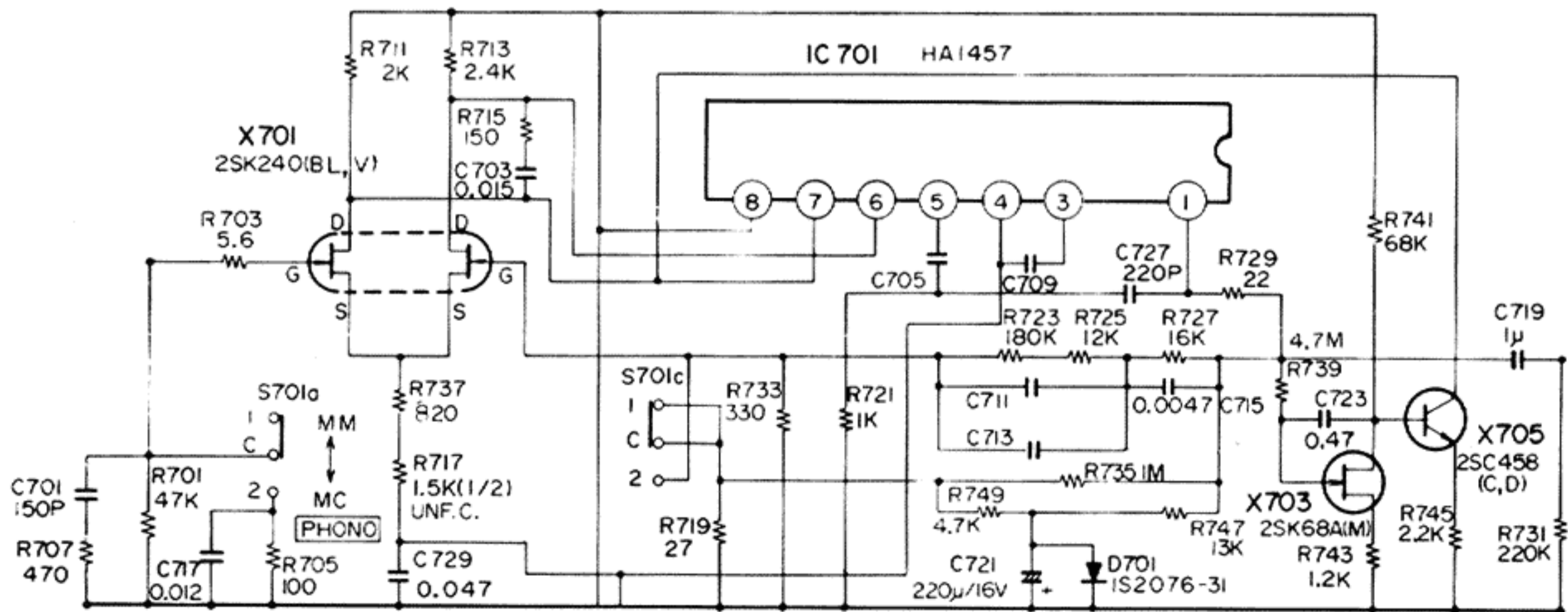
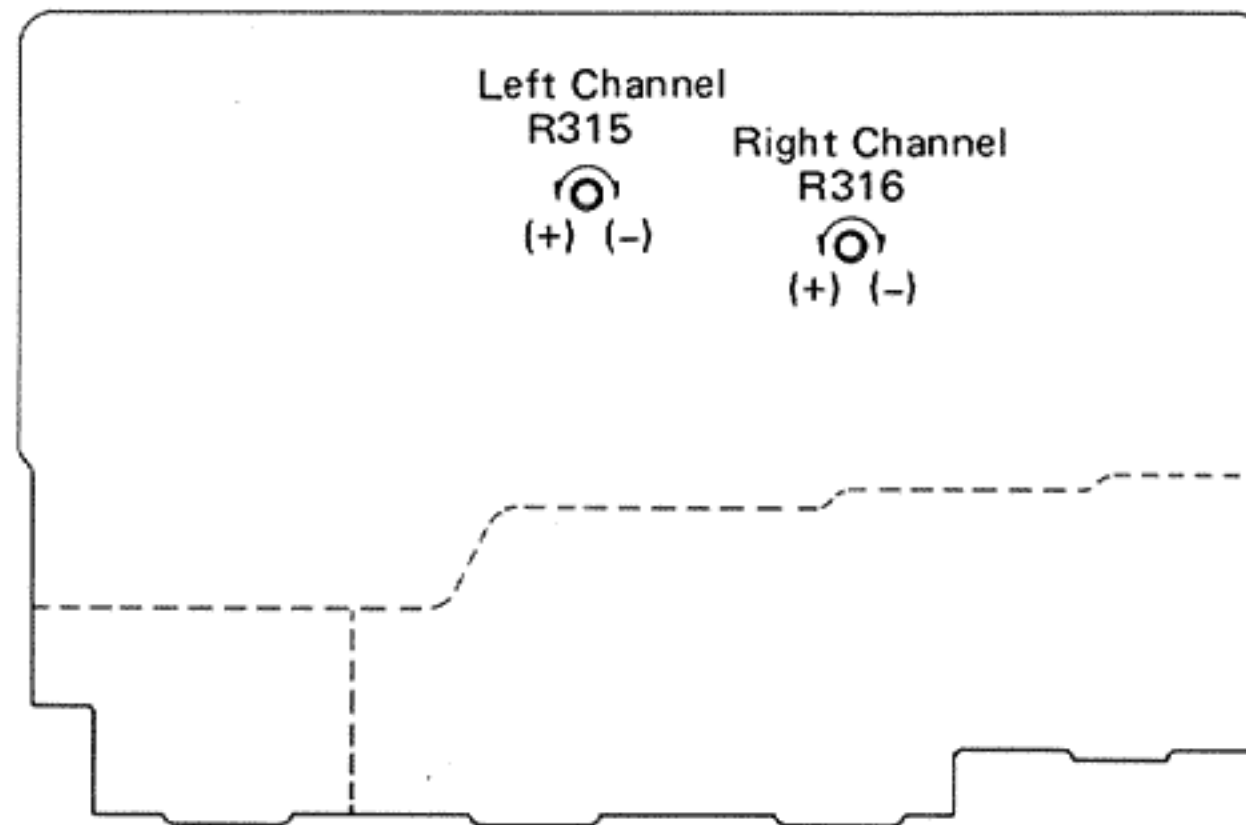

Fig. 10

7. Power Amplifier Adjustment Procedures



TAP-281 Driver Amp. P.C. Board Ass'y

Fig. 11

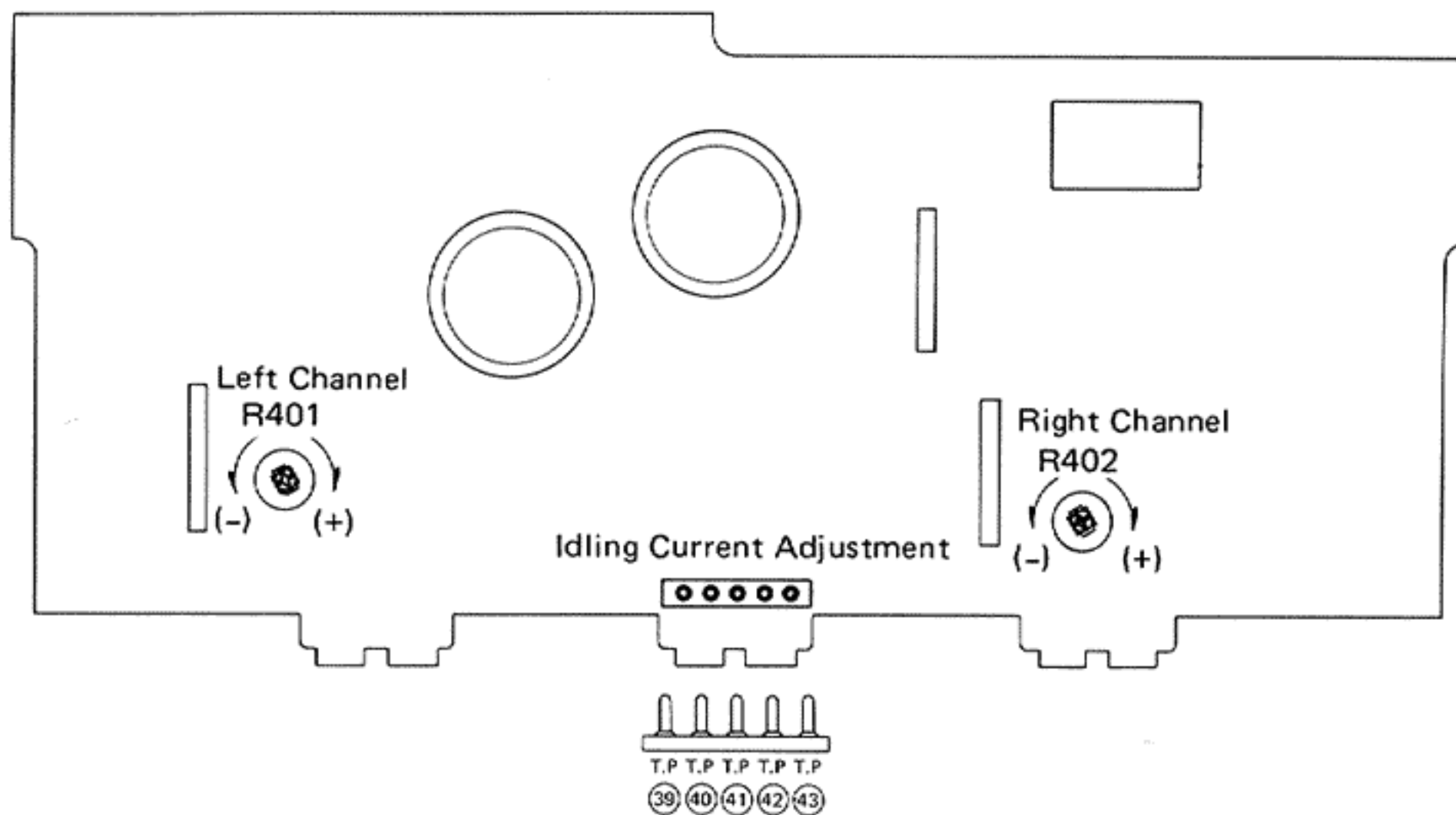

TXX-215-1 Power Amp. & Power Supply P.C. Board Ass'y

Fig. 12

7-(1) Center Voltage

1. Before turning on the power, set the semi-fixed resistors <R315 for L channel and R316 for R channel> of the drive amplifier circuit boards (TAP-281) to the center position.
2. Adjust the semi-fixed resistors (R315 and R316) so that the voltage at the following test points of the power amplifier circuit board (TXX-215-1) is within a range of ± 10 mV or less 5 minutes after the power is turned on.
L channel: Measure the voltage between test point 39 and test point 41 (ground).
R channel: Measure the voltage between test point 43 and test point 41 (ground).

The measurements can also be performed at the speaker terminals if the relay is operating normally.

7-(2) Idling Current

1. Before turning on the power, turn the semi-fixed resistors <R401 for L channel and R402 for R channel> of the power amplifier circuit board fully counterclockwise.

2. Adjust the semi-fixed resistors (R401 and R402) so that the voltage at the following test points of the power amplifier circuit board is within a range of 10 mV – 14 mV after the power is turned on.

L channel: Measure the voltage between test point 40 (emitter of X355) and output at the test point 39.

R channel: Measure the voltage between test point 42 (emitter of X356) and output at the test point 43.

3. Readjust resistors R401 and R402 about 5 minutes after the power is turned on (the heat sink temperature must be sufficiently high) so that the voltage at the test points becomes 12 mV.

Confirm that the voltage does not vary when the heat sink temperature increases further.

Note: Be sure to perform the measurement with the probes and cabinet of the measuring equipment separated from the grounding terminals of A-X3 or of other measuring equipment.

8. Printed Circuit Board Ass'y and Parts List

8-(1) TDS-5 LED Power Supply P.C. Board Ass'y

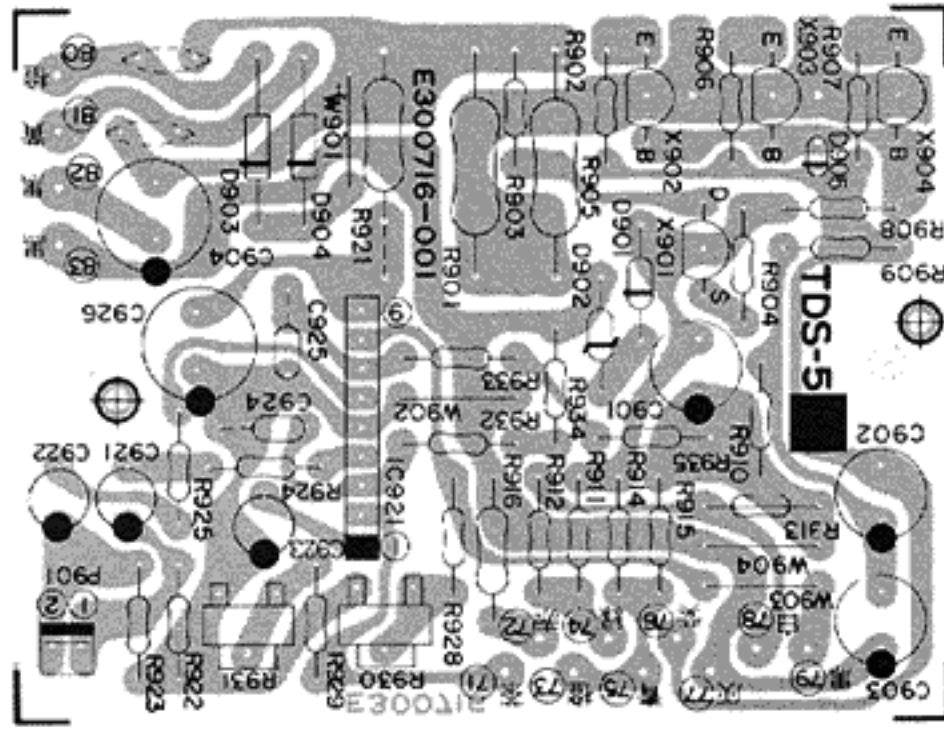

Fig. 13

Capacitors

Item No.	Part Number	Rating	Description
C922	QET51HR-105	1 μ F 50 V	Electrolytic
C923	QET51HR-474	0.47 μ F "	"
C924	QFM31HK-332	0.022 μ F "	Mylar
C925	QFM31HK-332	" "	"
C926	QET51ER-227H	220 μ F 25V	Electrolytic

Resistors

Item No.	Part Number	Rating	Description
R901	QRG027J-391	390 Ω 2 W	Oxide Metal Film
R902	QRG027J-391	" "	"
R903	QRD148J-332S	3.3 k Ω 1/4 W	Carbon
R904	QRD148J-820S	82 Ω "	"
R905	QRD149J-130S	13 Ω "	"
R906	QRD149J-130S	" "	"
R907	QRD149J-130S	" "	"
R908	QRD149J-471S	470 Ω "	"
R909	QRD148J-104S	100 k Ω "	"
R910	QRD148J-104S	" "	"
R911	QRD148J-273S	27 k Ω "	"
R912	QRD148J-183S	18 k Ω "	"
R914	QRD148J-393S	39 k Ω "	"
R915	QRD148J-222S	2.2 k Ω "	"
R916	QRD129J-471	470 Ω 1/2 W	"
R921	QRG017J-182S	1.8 k Ω 1 W	Oxide Metal Film
R922	QRD148J-104S	100 k Ω 1/4 W	Carbon
R923	QRD148J-104S	" "	"
R924	QRD148J-623S	62 k Ω "	"
R925	QRD148J-623S	" "	"
R928	QRD148J-132S	1.3 k Ω "	"
R929	QRD148J-132S	" "	"
R930	QVP9A0B-102	1 k Ω "	Variable
R931	QVP9A0B-102	" "	"

Transistors

Item No.	Part Number	Rating		Description	
		Pc	f _T	Maker	Maker
X901	2SK105(H)	0.25 W		F.E.T.	NEC
X902	2SC2235(O,Y)	0.9 W	120 MHz	Silicon	Toshiba
X903	2SC2235(O,Y)	"	"	"	"
X904	2SC2235(O,Y)	"	"	"	"

Integrated Circuits

Item No.	Part Number	Rating	Description	Maker
IC921	TA7318P(1)	700 mW	IC	Toshiba

Diodes

Item No.	Part Number	Rating	Description	Maker
D901	1S2076-31	13 V	Silicon	Hitachi
D902	RD13EB3		Silicon (Zener)	NEC
D903	ERB12-02RKL1		Silicon	Fuji
D904	ERB12-02RKL1		"	"
D905	VD1220		Silicon (Varistor)	NEC

Capacitors

Item No.	Part Number	Rating	Description
C901	QET51ER-226	22 μ F 25 V	Electrolytic
C902	QET51CR-107H	100 μ F 16 V	"
C903	QET51CR-107H	" "	"
C904	QET51JR-107H	" 63 V	"
C921	QET51HR-105	1 μ F 50 V	"

Others

Item No.	Part Number	Rating	Description
J803	EWS014-021		4Pin Socket Wire Ass'y (To TXX-215-1)
J903	EWS075-001		5Pin Socket Wire Ass'y (To TDS-5)
J904	EWS075-002		"
P901	QMV5005-002		2 Pin Plug Ass'y
	E300716-001		Cir. Board
	E67106-001		Bracket

8-(2) TXX-215 Power amp. Power Supply and Speakers P.C. Board Ass'y

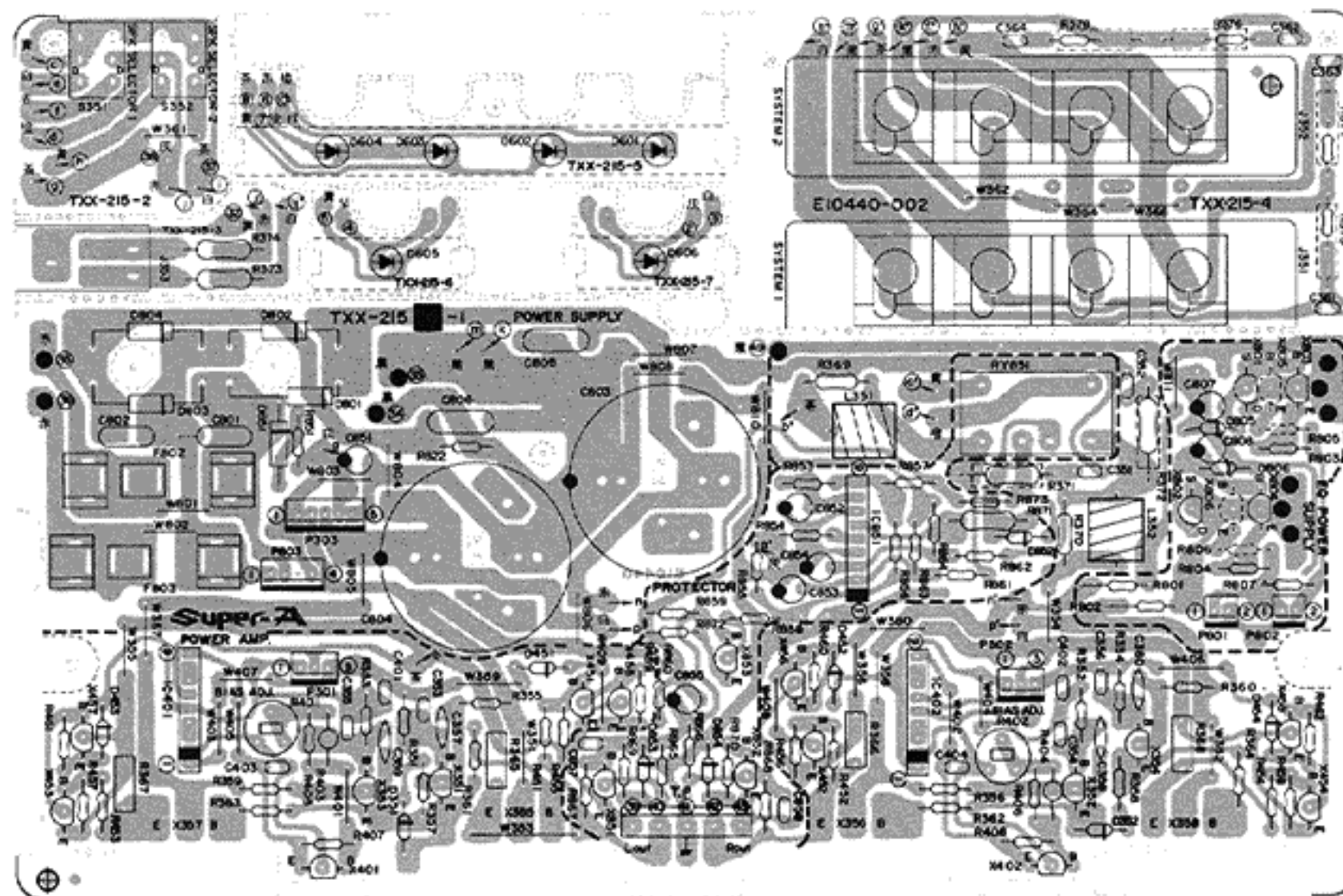

Fig. 14

△ : Safety Parts

Each Individual P.C. Board Location

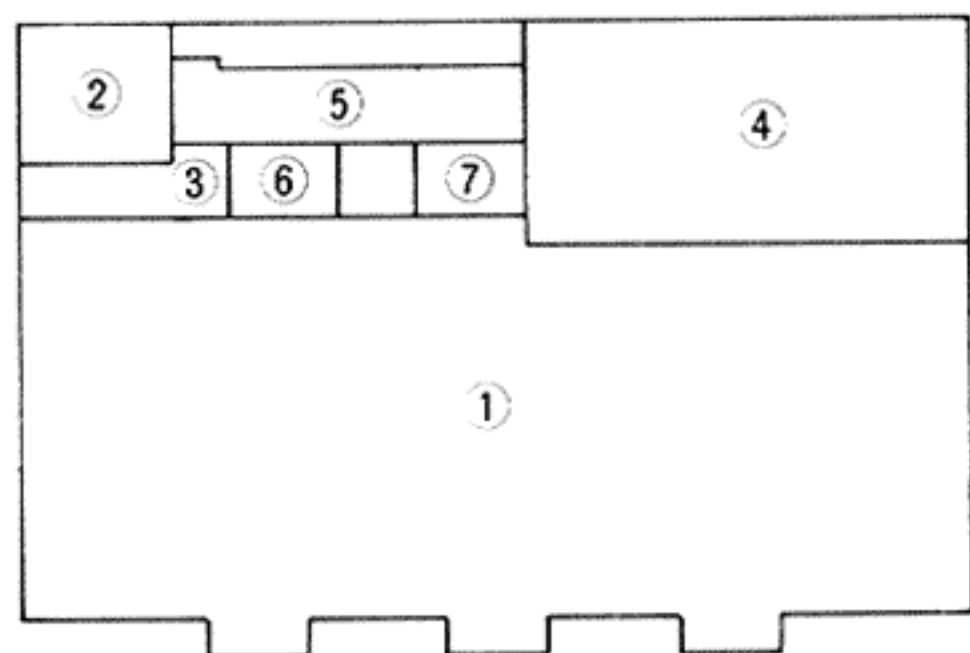

Fig. 15

- ① TXX-215-1 Power Amp. P.C.B. Ass'y
- ② TXX-215-2 Speaker Select Switch P.C.B. Ass'y
- ③ TXX-215-3 Head Phones P.C.B. Ass'y
- ④ TXX-215-4 Speaker Terminal P.C.B. Ass'y
- ⑤ TXX-215-5 L.E.D. P.C.B. Ass'y
- ⑥ TXX-215-6 " "
- ⑦ TXX-215-7 " "

Note:

The specific symbols (赤, 黒, 白, . . . etc.) on a surface of above P.C. Board are actually unrelated to the repair service and are significant denotement in order to process the proper assembly of P.C. Board at the factory.

Transistors

Item No.	Part Number	Rating		Description	Maker
		Pc	f _T		
X351	2SC2235(O,Y)	0.9 W	120 MHz	Silicon	Toshiba
X352	2SC2235(O,Y)	"	"	"	"
X353	2SA965(O,Y)	"	"	"	"
X354	2SA965(O,Y)	"	"	"	"
X355	2SC2564(O,Y)	120 W	90 MHz	"	"
X356	2SC2564(O,Y)	"	"	"	"
X357	2SA1094(O,Y)	"	70 MHz	"	"
X358	2SA1094(O,Y)	"	"	"	Hitachi
X401	2SC2546(E,F)	0.4 W	90 MHz	"	"
X402	2SC2546(E,F)	"	"	"	"
X451	2SC458(C,D)	0.2 W	230 MHz	"	"
X452	2SC458(C,D)	"	"	"	"
X453	2SA1029(C,D)	"	200 MHz	"	"
X454	2SA1029(C,D)	"	"	"	"
X455	2SA1029(C,D)	"	"	"	"
X456	2SA1029(C,D)	"	"	"	"
X457	2SC458(C,D)	"	230 MHz	"	"
X458	2SC458(C,D)	"	"	"	"
X801	2SK105(F)	0.25 W	"	F.E.T.	NEC
X802	2SK105(F)	"	"	"	"
X803	2SC2235(O,Y)	0.9 W	120 MHz	Silicon	Toshiba
X804	2SA965(O,Y)	"	"	"	"
X851	2SC1775AV(F)	0.2 W	200 MHz	"	Hitachi
X852	2SC1775AV(F)	"	"	"	"
X853	2SA872AV(E)	0.3 W	120 MHz	"	"

Diodes

Item No.	Part Number	Rating	Description	Maker
D603	SG203TA		L.E.D.	NEC
D604	SY403TA		"	"
D605	SG203TA		"	"
D606	SY403TA		"	"
D801	30D2FA-S		Silicon	Nihon Inter.
D802	30D2FA-S		"	"
D803	30D2FA-S		"	"
D804	30D2FA-S		"	"
D805	RD27EB3		Silicon(Zener)	NEC
D806	RD27EB3		"	"
D851	ERB12-02RKL1		Silicon	Fuji
D852	1S2076-31		"	Hitachi
D853	1S2076-31		"	"

Coil & Transformers

Item No.	Part Number	Rating	Description
L351	E04059-1R0	1 μH	Choke Coil
L352	E04059-1R0	"	"

Capacitors

Item No.	Part Number	Rating		Description
C351	QFM31HK-223	0.022 μF	50 V	Mylar
C352	QFM31HK-223	"	"	"
C353	QFM31HK-152	1500 pF	"	"
C354	QFM31HK-152	"	"	"
C355	QCS21HJ-471	470 pF	"	Ceramic
C356	QCS21HJ-471	"	"	"
C357	QCS21HJ-220	22 pF	"	"
C358	QCS21HJ-220	"	"	"
C359	QCS21HJ-220	"	"	"
C360	QCS21HJ-220	"	"	"
C361	QFM31HK-103	0.01 μF	"	Mylar
C362	QFM31HK-103	"	"	"
C363	QFM31HK-103	"	"	"
C364	QFM31HK-103	"	"	"
C401	QFM31HK-332	3300 pF	"	"
C402	QFM31HK-332	"	"	"
C403	QFM31HK-103	0.01 μF	"	"
C404	QFM31HK-103	"	"	"
C801	QCE22HP-103	"	500 V	Ceramic (U.S.A. & Canada)
C801	QFZ0074-104	0.1 μF	250 V	Ceramic (Except U.S.A. & Canada)

Integrated Circuits

Item No.	Part Number	Rating	Description	Maker
IC401	VC5022		I.C.	Toyodengu
IC402	VC5022		"	"
IC851	TA7317P	0.5 W	"	Toshiba

Diodes

Item No.	Part Number	Rating	Description	Maker
D351	1S2076-31		Silicon	Hitachi
D352	1S2076-31		"	"
D451	1S2076-31		"	"
D601	SG203TA		L.E.D.	NEC
D602	SG203TA		"	"

⚠ : Safety Parts

Capacitors

Item No.	Part Number	Rating		Description
C802	QCE22HP-103	0.01 μ F	500 V	Ceramic
C803	EEW5601-878	8700 μ F	56 V	Electrolytic
C804	EEW5601-878	"	"	"
C807	QET51HR-106H	10 μ F	50 V	Tantalum Electrolytic
C808	QET51HR-106H	"	"	"
C851	QET51HR-105H	1 μ F	"	"
C852	QET51CR-226H	22 μ F	16 V	"
C853	QET51AR-476H	47 μ F	10 V	"
C854	QET51AR-476H	"	"	"
C855	QET51HR-106H	10 μ F	50 V	"
C857	QFM31HK-103	0.01 μ F	"	Mylar
C858	QFM31HK-103	"	"	"

Resistors

Item No.	Part Number	Rating		Description
R351	QRZ0052-181	180 Ω	1/4 W	Carbon (Fuse) \triangle
R352	QRZ0052-181	"	"	" \triangle
R353	QRZ0052-181	"	"	" \triangle
R354	QRZ0052-181	"	"	" \triangle
R355	QRZ0052-100	10 Ω	"	" \triangle
R356	QRZ0052-100	"	"	" \triangle
R357	QRZ0052-271	270 Ω	1/4 W	" \triangle
R358	QRZ0052-271	"	"	" \triangle
R359	QRZ0052-100	10 Ω	"	" \triangle
R360	QRZ0052-100	"	"	" \triangle
R361	QRD149J-5R6S	5.6 Ω	"	Carbon \triangle
R362	QRD149J-5R6S	"	"	" \triangle
R363	QRD149J-5R6S	"	"	" \triangle
R364	QRD149J-5R6S	"	"	" \triangle
R365	QRM054K-R22	0.22 Ω	5 W	Metal Plate \triangle
R366	QRM054K-R22	"	"	" \triangle
R367	QRM054K-R22	"	"	" \triangle
R368	QRM054K-R22	"	"	" \triangle
R369	QRD129J-4R7	4.7 Ω	1/2 W	Carbon \triangle
R370	QRD129J-4R7	"	"	" \triangle
R371	See Page 19	10 Ω	"	" \triangle
R372	See Page 19	"	"	" \triangle
R373	QRG017J-331S	330 Ω	"	Ox. Metal Film \triangle
R374	QRG017J-331S	"	"	" \triangle
R375	See Page 19	10 Ω	"	" \triangle
R376	See Page 19	"	"	" \triangle
R377	See Page 19	"	"	" \triangle
R378	See Page 19	"	"	" \triangle
R401	QVP4A0B-221	220 Ω	0.15 W	Variable
R402	QVP4A0B-221	"	"	"
R403	SDT35	350 Ω	1 W	Thermistor
R404	SDT35	"	"	"
R405	QRD141J-331SY	330 Ω	1/4 W	Carbon
R406	QRD141J-331SY	"	"	"
R407	QRD141J-821SY	820 Ω	"	"
R408	QRD141J-821SY	"	"	"
R451	QRD141J-102SY	1 k Ω	"	"
R452	QRD141J-102SY	"	"	"
R453	QRD141J-102SY	"	"	"
R454	QRD141J-102SY	"	"	"
R455	QRD141J-102SY	"	"	"
R456	QRD141J-102SY	"	"	"
R457	QRD141J-102SY	"	"	"
R458	QRD141J-102SY	"	"	"
R459	QRD141J-103SY	10 k Ω	"	"
R460	QRD141J-103SY	"	"	"
R461	QRD141J-103SY	"	"	"
R462	QRD141J-103SY	"	"	"
R801	QRZ0052-820	82 Ω	"	Carbon (Fuse) \triangle
R802	QRZ0052-820	"	"	" \triangle

Resistors

Item No.	Part Number	Rating		Description
R803	QRD149J-820S	82 Ω	1/4W	Carbon \triangle
R804	QRD149J-820S	"	"	" \triangle
R807	QRD141J-224SY	220 k Ω	"	"
R822	QRD141J-223SY	22 k Ω	"	"
R851	QRD149J-331S	330 Ω	"	" \triangle
R853	QRD141J-224SY	220 k Ω	"	"
R854	QRD141J-103SY	10 k Ω	"	"
R855	QRD141J-204SY	200 k Ω	"	"
R856	QRD141J-683SY	68 k Ω	"	"
R857	QRD141J-223SY	22 k Ω	"	"
R858	QRD141J-473SY	47 k Ω	"	"
R859	QRD141J-103SY	10 k Ω	"	"
R860	QRD149J-270S	27 Ω	"	" \triangle
R861	QRD141J-563SY	56 k Ω	"	"
R862	QRD141J-563SY	"	"	"
R863	QRD141J-273SY	27 k Ω	"	"
R864	QRD141J-273SY	"	"	"
R865	QRD141J-223SY	22 k Ω	"	"
R866	QRD141J-223SY	"	"	"
R867	QRD141J-681SY	680 Ω	"	"
R868	QRD141J-681SY	"	"	"
R869	QRD141J-562SY	5.6 k Ω	"	"
R870	QRD141J-562SY	"	"	"
R871	QRG017J-102S	1 k Ω	1 W	Ox. Metal Film \triangle
R872	QRD141J-332SY	3.3 k Ω	1/4 W	Carbon

Others

Item No.	Part Number	Rating	Description
J351	E03572-011		Speaker Terminal
J352	E03572-011		"
J353	QMS6302-105		Head Phone Jack Ass'y
J602	EWS014-015		4P Socket Wire Ass'y (To TXX-216-2)
J604	EWS015-013		5P Socket Wire Ass'y (To TXX-216-1)
J901	EWS012-010		2P Socket Wire Ass'y (To TDS-5)
P301	QMV5005-003		3P Plug Ass'y
P302	QMV5005-003		" "
P303	QMV5005-005		5P "
P801	QMV5005-002		2P "
P803	QMV5005-004		4P "
RY851	ESK6D24-213		Relay Switch
	See Page 19		Fuse Clip
	See Page 19		Fuse Label
	E300209-005		Heat Sink
	E03628-5UD		5P Plug Ass'y (Test Point)
	E300508-001		4 L.E.D. Holder
	E43727-002		Tab
	E65468-007		Heat Sink Bracket
	E67105-001		Clip (X401, 402)
	E66689-001		1 L.E.D. Holder
	LPSP3014NS		Screw
	QSP0229-103		Push Switch (Speaker)
	SBSB3008Z		Tapping Screw
	E66998-002		IC Cap

\triangle : Safety Parts

8-(3) TXX-216 Equalizer Amp. and Source Selector P.C. Board Ass'y

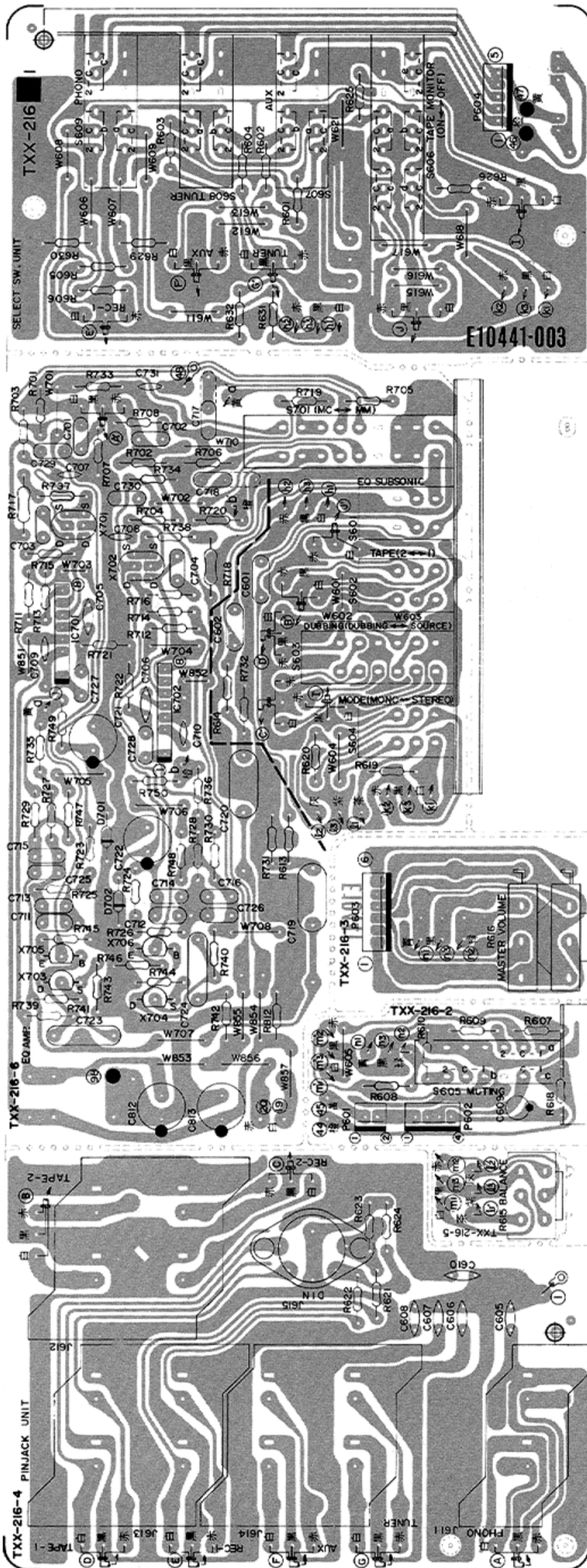

Fig. 16

Each Individual P.C. Board Location

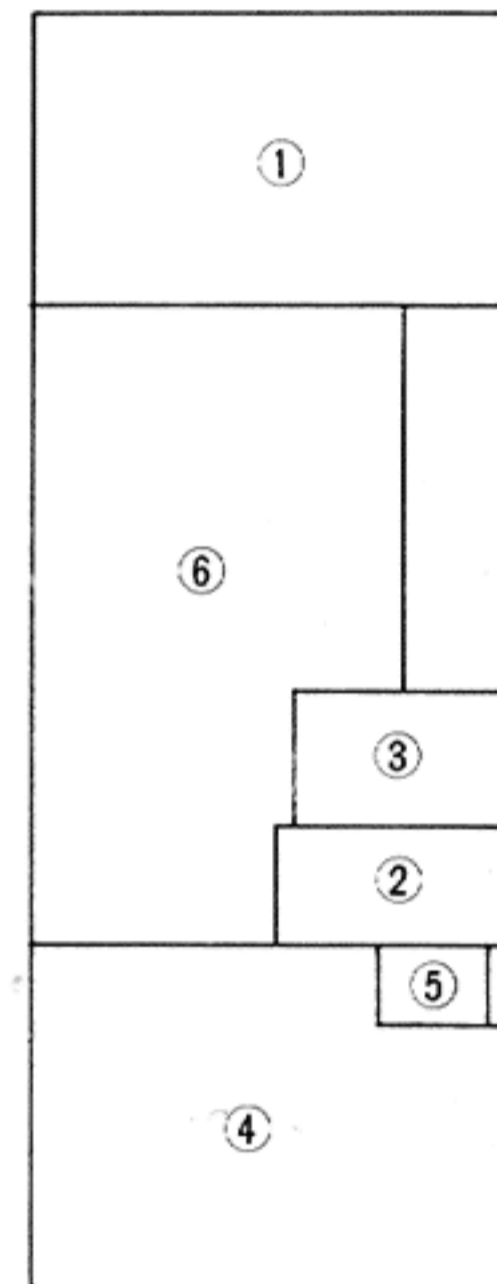

Fig. 17

- ① TXX-216-1 Select Switch P.C.B. Ass'y
- ② TXX-216-2 Muting Switch P.C.B. Ass'y
- ③ TXX-216-3 Volume P.C.B. Ass'y
- ④ TXX-216-4 Pin Jack P.C.B. Ass'y
- ⑤ TXX-216-5 Balance Control P.C.B. Ass'y
- ⑥ TXX-216-6 EQ Amp. & Switch P.C.B. Ass'y

Note:

The specific symbols (赤, 黒, 白, ... etc.) on a surface of above P.C. Board are actually unrelated to the repair service and are significant denotement in order to process the proper assembly of P.C. Board at the factory.

Transistors

Item No.	Part Number	Rating		Description	
		Pc	f _T	F.E.T.	Maker
X701	2SK240(BL,V)	0.4 W	90 MHz	F.E.T.	Toshiba
X702	2SK240(BL,V)			"	"
X703	2SK68A(M)			"	"
X704	2SK68A(M)	"	"	"	"
X705	2SC458(C,D)	0.2 W	230 MHz	Silicon	Hitachi
X706	2SC458(C,D)	"	"	"	"

Resistors

Item No.	Part Number	Rating		Description
		Resistance	Power	
R601	QRD141J-331SY	330 Ω	1/4 W	Carbon
R602	QRD141J-331SY	"	"	"
R603	QRD141J-331SY	"	"	"
R604	QRD141J-331SY	"	"	"
R605	QRD141J-331SY	"	"	"
R606	QRD141J-331SY	"	"	"
R607	QRD141J-823SY	82 kΩ	"	"
R608	QRD141J-823SY	"	"	"
R609	QRD141J-103SY	10 kΩ	"	"
R610	QRD141J-103SY	"	"	"
R613	QRD141J-331SY	330 Ω	"	"
R614	QRD141J-331SY	"	"	"
R615	QVD7A3M-1F5V	250 kΩ	"	Variable (Balance Control)
R616	QVZ1221-002	100 kΩ	1/2 W	Variable (Master Volume)
R618	QRD141J-220SY	22 Ω	1/4 W	Carbon
R619	QRD141J-472SY	4.7 kΩ	"	"
R620	QRD141J-472SY	"	"	"
R621	QRD141J-334SY	330 kΩ	"	Carbon (Except U.S.A. & Canada)
R622	QRD141J-334SY	"	"	"
R623	QRD141J-104SY	100 kΩ	"	"
R624	QRD141J-104SY	"	"	"
R625	QRD141J-331SY	330 Ω	"	Carbon
R626	QRD141J-331SY	"	"	"
R629	QRD141J-105SY	1 MΩ	"	"
R630	QRD141J-105SY	"	"	"
R631	QRD141J-100SY	10 Ω	"	"
R632	QRD141J-100SY	"	"	"
R701	QRD141J-473SY	47 kΩ	"	"
R702	QRD141J-473SY	"	"	"
R703	QRD141J-5R6SY	5.6 Ω	"	"
R704	QRD141J-5R6SY	"	"	"
R705	QRD141J-101SY	100 Ω	"	"
R706	QRD141J-101SY	"	"	"
R707	QRD141J-471SY	470 Ω	"	"
R708	QRD141J-471SY	"	"	"
R711	QRD141J-202SL	2 kΩ	"	"
R712	QRD141J-202SL	"	"	"
R713	QRD141J-242SL	2.4 kΩ	"	"
R714	QRD141J-242SL	"	"	"
R715	QRD141J-151SY	150 Ω	"	"
R716	QRD141J-151SY	"	"	"
R717	QRD129J-152	1.5 kΩ	1/2 W	"
R718	QRD129J-152	"	"	"
R719	QRD141J-270SY	27 Ω	1/4 W	"
R720	QRD141J-270SY	"	"	"
R721	QRD141J-102SY	1 kΩ	"	"
R722	QRD141J-102SY	"	"	"
R723	QRD141J-184SY	180 kΩ	"	"
R724	QRD141J-184SY	"	"	"
R725	QRD141J-123SY	12 kΩ	"	"
R726	QRD141J-123SY	"	"	"
R727	QRD141J-163SY	16 kΩ	"	"
R728	QRD141J-163SY	"	"	"
R729	QRD141J-220SY	22 Ω	"	"
R730	QRD141J-220SY	"	"	"
R731	QRD141J-224SY	220 kΩ	"	"
R732	QRD141J-224SY	"	"	"
R733	QRD141J-331SY	330 Ω	"	"
R734	QRD141J-331SY	"	"	"
R735	QRD141J-105SY	1 MΩ	"	"
R736	QRD141J-105SY	"	"	"
R737	QRD141J-821SY	820 Ω	"	"
R738	QRD141J-821SY	"	"	"
R739	QRD141J-475SY	4.7 MΩ	"	"
R740	QRD141J-475SY	4.7 MΩ	"	"
R741	QRD141J-683SY	68 kΩ	"	"

Integrated Circuits

Item No.	Part Number	Rating		Description	Maker
		Pc	f _T		
IC701	HA1457	0.5 W	"	I.C.	Hitachi
IC702	HA1457	"	"	"	"

Diodes

Item No.	Part Number	Rating	Description	Maker
				Hitachi
D701	1S2076-31		Silicon	Hitachi
D702	1S2076-31		"	"

Capacitors

Item No.	Part Number	Rating		Description
		Value	Voltage	
C601	QFM31HK-224	0.22 μF	50 V	Mylar
C602	QFM31HK-224	"	"	"
C605	QCF21HP-473	0.022 μF	"	Ceramic
C606	QCF21HP-103A	"	"	"
C607	QCF21HP-103A	"	"	"
C608	QCF21HP-103A	"	"	"
C609	QET51AR-476	47 μF	10 V	Electrolytic
C610	QCF21HP-103A	0.022 μF	50 V	Ceramic
C701	QCS21HJ-151	150 pF	"	"
C702	QCS21HJ-151	"	"	"
C703	QFM31HK-153	0.015 μF	"	Mylar
C704	QFM31HK-153	"	"	"
C705	QCS21HJ-680	68 pF	"	Ceramic
C706	QCS21HJ-680	"	"	"
C709	QCS21HJ-560	56 pF	"	"
C710	QCS21HJ-560	"	"	"
C711	QFM31HJ-822	8200 pF	"	Mylar
C712	QFM31HJ-822	"	"	"
C713	QFM31HJ-822	"	"	"
C714	QFM31HJ-822	"	"	"
C715	QFM31HJ-472	4700 pF	"	"
C716	QFM31HJ-472	"	"	"
C717	QFM31HK-123	0.012 μF	"	"
C718	QFM31HK-123	"	"	"
C719	EFZ0080-105	1 μF	200 V	Film
C720	EFZ0080-105	"	"	"
C721	QET51CR-227H	220 μF	16 V	Tantalum Electrolytic
C722	QET51CR-227H	"	"	"
C723	QFH42AK-474	0.47 μF	100 V	Metallized Mylar
C724	QFH42AK-474	"	"	"
C727	QCS21HJ-221	220 pF	50 V	Ceramic
C728	QCS21HJ-221	"	"	"
C729	QFM31HK-473	0.047 μF	"	Mylar
C730	QFM31HK-473	"	"	"
C731	QCF21HP-473	"	"	Ceramic
C812	QET51ER-227E	220 μF	25 V	Electrolytic
C813	QET51ER-227E	"	"	"

Resistors

Item No.	Part Number	Rating	Description
R742	QRD141J-683SY	68 kΩ	1/4 W Carbon
R743	QRD141J-122SY	1.2 kΩ	"
R744	QRD141J-122SY	"	"
R745	QRD141J-222SY	2.2 kΩ	"
R746	QRD141J-222SY	"	"
R747	QRD141J-133SY	13 kΩ	"
R748	QRD141J-133SY	"	"
R749	QRD141J-472SY	4.7 kΩ	"
R750	QRD141J-472SY	"	"
R812	QRD141J-912SY	9.1 kΩ	"

Others

Item No.	Part Number	Rating	Description
J611	E03591-22DS		2Pin Jack Ass'y
J612	E03591-42D		4Pin "
J613	E03591-42D		" "
J614	E03591-42D		" "
J615	E03623-003		Din Socket Ass'y (Except U.S.A.&Canada)
J801	EWS012-009		2P Socket Wire Ass'y (To TXX-215-1)
P601	QMV5005-002		2P Plug Ass'y
P602	QMV5005-004		4P "
P603	QMV5005-006		6P "
P604	QMV5005-005		5P "
S605	QSP0210-104		Push Switch (Muting)
4KEY	QSP0249-112		Push Switch
5KEY	QSP0259-003		"
	EWT011-018		Terminal Wire Ass'y

8-(4) TPS-234 AC Socket P.C. Board Ass'y

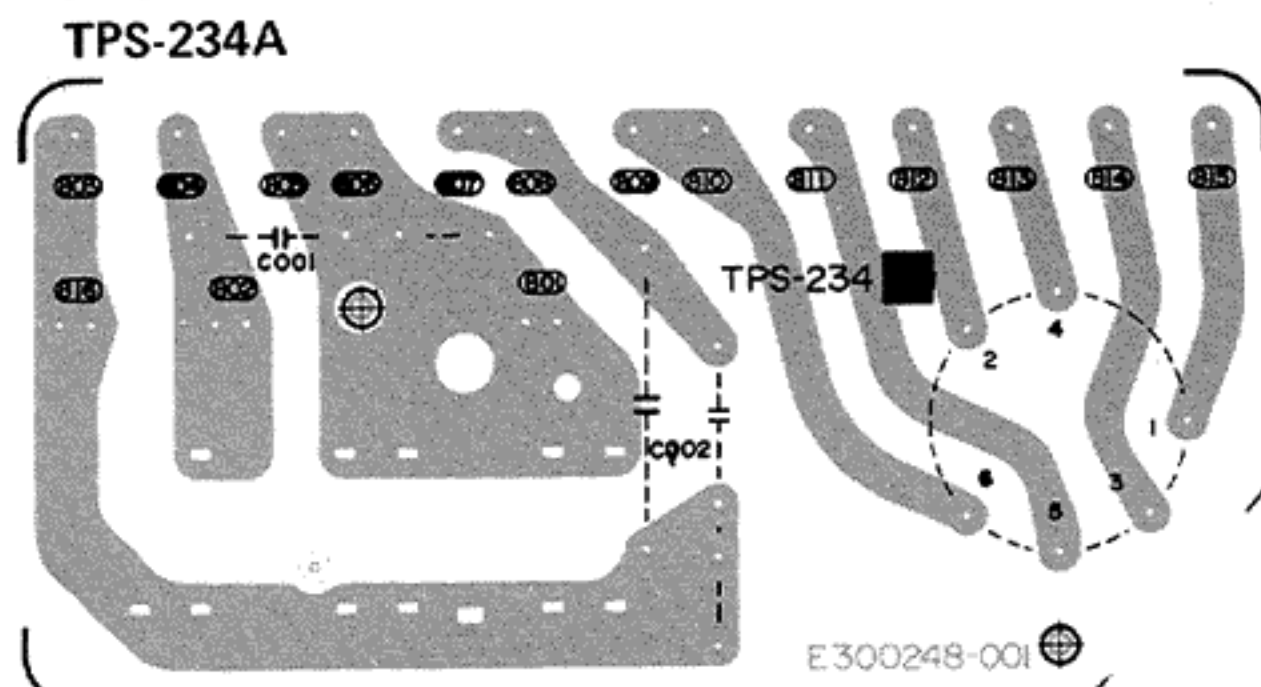

For U.S. Military Market and
Other Countries

Fig. 18

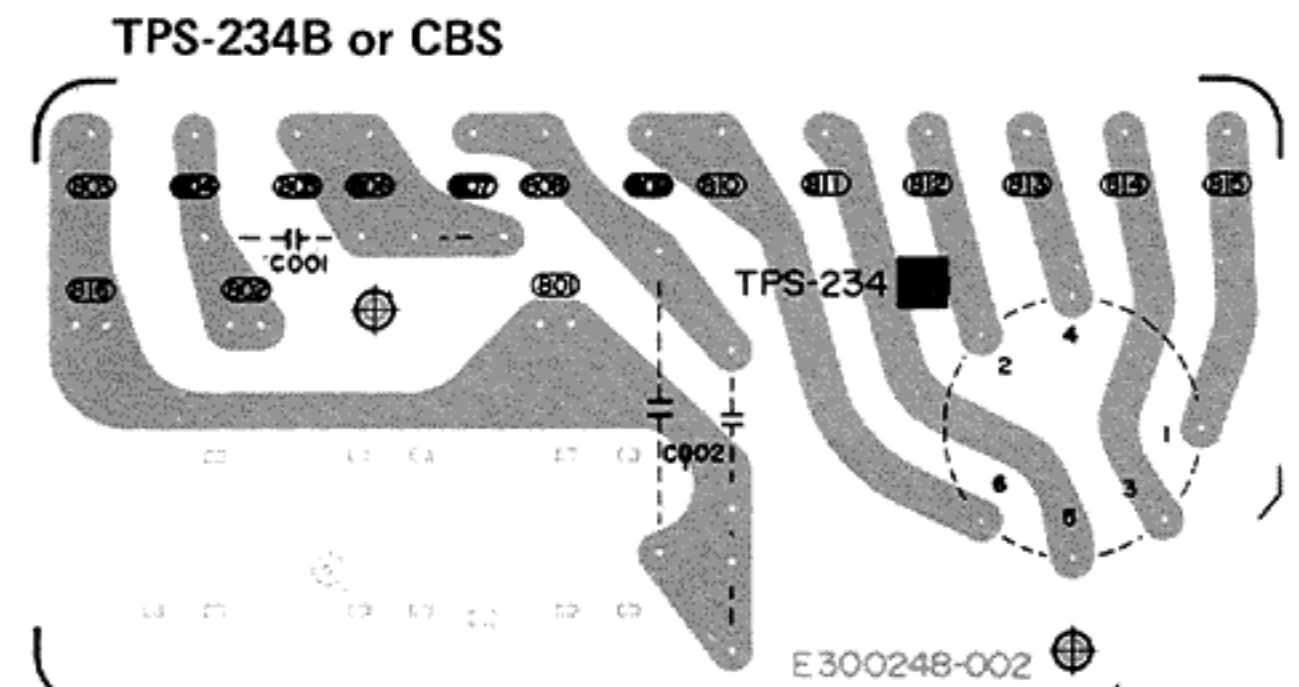

TPS-234B : for Australia & Europe
TPS-234CBS : for U.K.

Fig. 19

Item No.	Description	Part Number		
		TPS-234A	TPS-234B	TPS-23CBS
C001/C002	Film Capacitor ⚠	QFH53BM-103 (0.01 μF/AC 500 V)	QFZ29007-103 (0.01 μF/AC 450 V)	QFZ29007-103BS (0.01 μF/AC 450 V)
	AC Outlets ⚠	QMC0637-003	-	-
	Tab (Long)	E43727-001	E43727-001	E43727-001
	Tab (Short)	E65508-001	E65508-001	E65508-001
	Bracket	-	E65586-002	E65586-002
	Tapping Screw	-	SBSB3008Z	SBSB3008Z
	Voltage Selector ⚠	QSR0085-001	QSR0085-001	QSR0085-001BS

8-(5) TPS-255 AC Fuse P.C. Board Ass'y

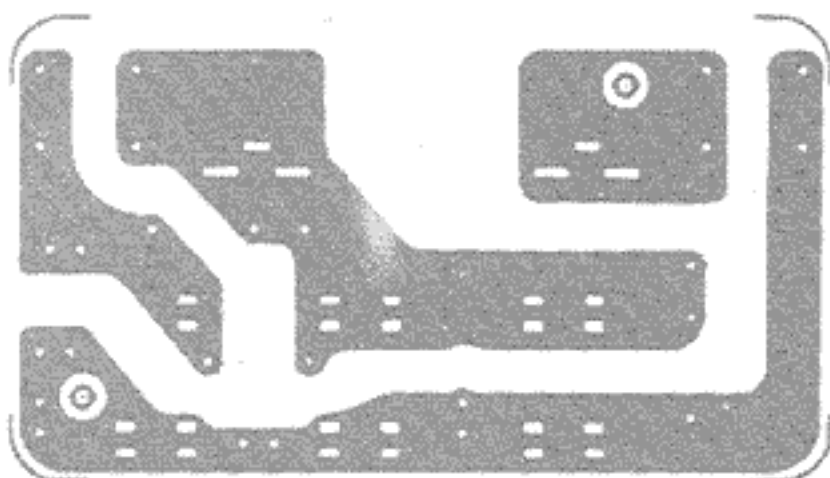

Fig. 20

Note:

The specific symbols (赤, 黒, 白, ... etc.) on a surface of above P.C. Board are actually unrelated to the repair service and are significant denotement in order to process the proper assembly of P.C. Board at the factory.

TPS-255B for U.S.A. & Canada

Capacitors

Item No.	Part Number	Rating	Description
C001	QCZ9014-103A	0.01 μF 125 V	Ceramic ⚠

Others

Item No.	Part Number	Rating	Description
J811	QMC0637-003		AC Outlet ⚠
	E03675-004		Fuse Clip ⚠
	E43727-001		Tab (Long)
	E65508-001		Tab (Short)

⚠ : Safety Parts

8-(6) TAP-281 Driver Amp. P.C. Board Ass'y

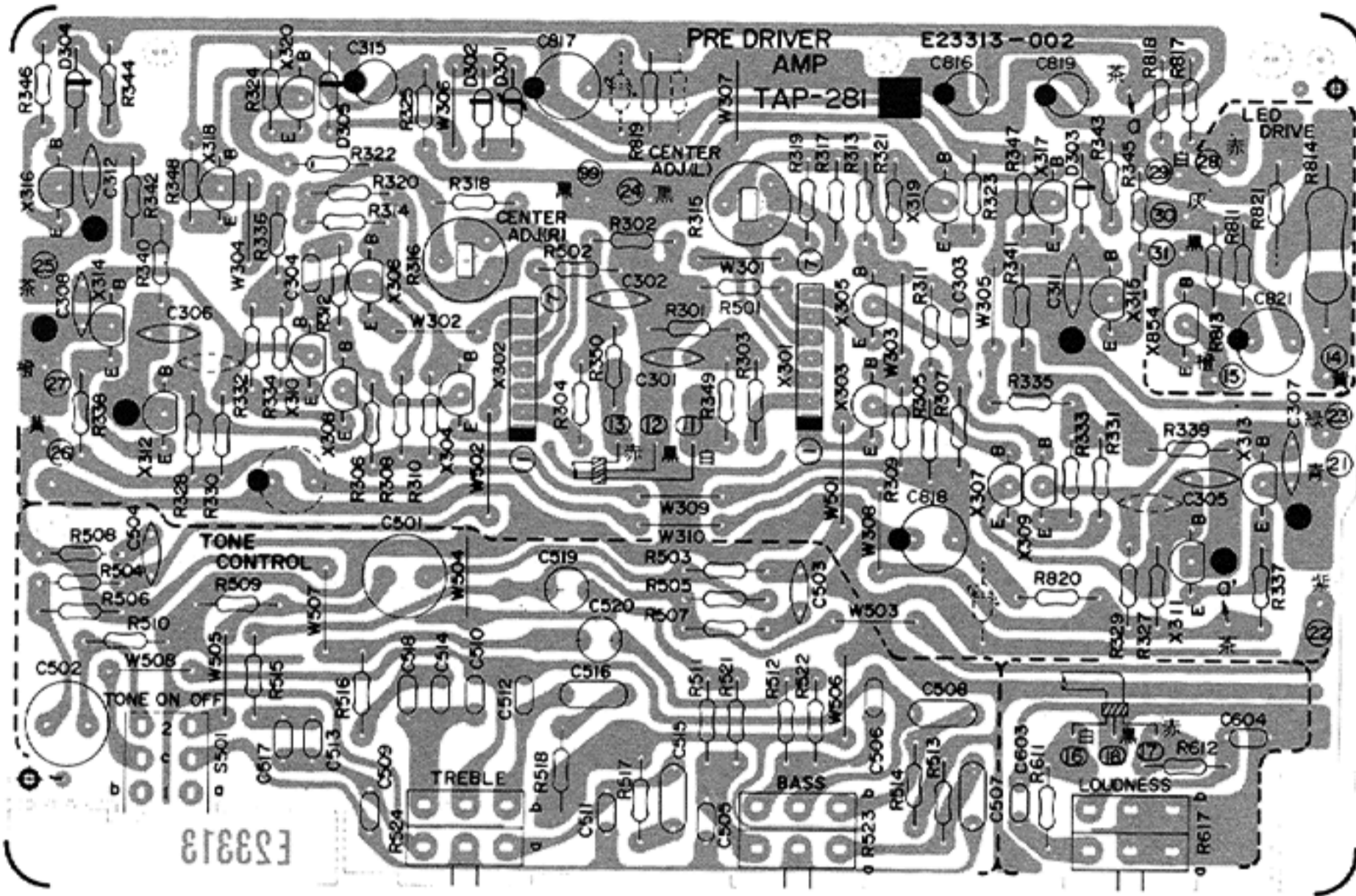

Note:

The Specific symbols (赤, 黒, 白, . . . etc.) on a surface of above P.C. Board are actually unrelated to the repair service and are significant denotement in order to process the proper assembly of P.C. Board at the factory.

Fig. 21

Transistors

Item No.	Part Number	Rating		Description	
		Pc	f _T		Maker
X301	2SK150A(GR,BL)	0.2 W/ Unit	230 MHz	Dual	Toshiba
X302	2SK150A(GR,BL)			"	"
X303	2SC458(C,D)			Silicon	Hitachi
X304	2SC458(C,D)			"	"
X305	2SC458(C,D)			"	"
X306	2SC458(C,D)	"	"	"	"
X307	2SC458(C,D)	"	"	"	"
X308	2SC458(C,D)	"	"	"	"
X309	2SC458(C,D)	"	"	"	"
X310	2SC458(C,D)	"	"	"	"
X311	2SA872AV(D,E)	0.3 W	120 MHz	"	"
X312	2SA872AV(D,E)			"	"
X313	2SA872AV(D,E)			"	"
X314	2SA872AV(D,E)			"	"
X315	2SC1775AV(E,F)			0.2 W	200 MHz
X316	2SC1775AV(E,F)	"	230 MHz	"	"
X317	2SC458(C,D)			"	"
X318	2SC458(C,D)			"	"
X319	2SC458(C,D)			"	"
X320	2SC458(C,D)			"	"
X854	2SA1084(E)	0.4 W	120 MHz	"	"

Capacitors

Item No.	Part Number	Rating		Description
C303	QCS21HJ-471	470 pF	50 V	Ceramic
C304	QCS21HJ-471	"	"	"
C305	QCS21HJ-100	10 pF	"	"
C306	QCS21HJ-100	"	"	"
C307	QCS21HJ-150	15 pF	"	"
C308	QCS21HJ-150	"	"	"
C311	QCS21HJ-560	56 pF	"	"
C312	QCS21HJ-560	"	"	"
C315	QET51HR-105H	1 μF	"	Electrolytic
C501	QEZ0046-226	22 μF	"	"
C502	QEZ0046-226	"	"	"
C503	QCS21HJ-150	15 pF	"	Ceramic
C504	QCS21HJ-150	"	"	"
C505	QFM31HJ-333	0.033 μF	"	Mylar
C506	QFM31HJ-333	"	"	"
C507	QFM31HJ-224	0.22 μF	"	"
C508	QFM31HJ-224	"	"	"
C509	QCS21HJ-181	180 pF	"	Ceramic
C510	QCS21HJ-181	"	"	"
C511	QFM31HJ-122	1200 pF	"	Mylar
C512	QFM31HJ-122	"	"	"
C513	QFM31HJ-472	4700 pF	"	"
C514	QFM31HJ-472	"	"	"
C515	QFM31HJ-563	0.056 μF	"	"
C516	QFM31HJ-563	"	"	"
C517	QFM31HJ-272	2700 pF	"	"
C518	QFM31HJ-272	"	"	"
C519	QEZ0046-225	2.2 μF	"	Electrolytic
C520	QEZ0046-225	"	"	"
C603	QFM31HJ-183N	0.018 μF	50 V	Mylar
C604	QFM31HJ-183N	"	"	"
C816	QET51JR-225H	2.2 μF	63 V	Electrolytic
C817	QET51HR-476H	47 μF	50 V	"
C818	QET51HR-476H	"	"	"
C819	QET51JR-225H	2.2 μF	63 V	"
C821	QET50JR-227H	220 μF	6.3 V	"

Diodes

Item No.	Part Number	Rating	Description	Maker
D301	RD5.6EB3		Silicon (Zener)	NEC
D302	1S2076-31		Silicon	Hitachi
D303	1S2076-31		"	"
D304	1S2076-31		"	"
D305	1S2076-31		"	"

Resistors

Item No.	Part Number	Rating		Description
R301	QRD141J-105SY	1 MΩ	1/4 W	Carbon
R302	QRD141J-105SY	"	"	"
R303	QRD141J-470SY	47 Ω	"	"
R304	QRD141J-470SY	"	"	"
R305	QRD141J-123SY	12 kΩ	"	"
R306	QRD141J-123SY	"	"	"
R307	QRD141J-123SY	"	"	"
R308	QRD141J-123SY	"	"	"
R309	QRD141J-124SY	120 kΩ	"	"
R310	QRD141J-124SY	"	"	"
R311	QRD141J-331SY	330 Ω	"	"
R312	QRD141J-331SY	"	"	"
R313	QRD141J-563SY	56 kΩ	"	"
R314	QRD141J-563SY	"	"	"
R315	QVP4A0B-221	220 Ω		Variable
R316	QVP4A0B-221	"		"
R317	QRD141J-270SY	27 Ω	1/4 W	Carbon
R318	QRD141J-270SY	"	"	"
R319	QRD141J-270SY	"	"	"
R320	QRD141J-270SY	"	"	"
R321	QRD141J-562SY	5.6 kΩ	"	"
R322	QRD141J-562SY	"	"	"
R323	QRD141J-202SY	2 kΩ	"	"
R324	QRD141J-202SY	"	"	"
R325	QRD141J-273SY	27 kΩ	"	"
R327	QRZ0052-102	1 kΩ	"	Carbon (Fuse) ⚠
R328	QRZ0052-102	"	"	" ⚠
R329	QRZ0052-102	"	"	" ⚠
R330	QRZ0052-102	"	"	" ⚠
R331	QRD141J-220SY	22 Ω	"	Carbon
R332	QRD141J-220SY	"	"	"
R333	QRD141J-220SY	"	"	"
R334	QRD141J-220SY	"	"	"
R335	QRD141J-103SY	10 kΩ	"	"
R336	QRD141J-103SY	"	"	"
R337	QRZ0052-101	100 Ω	"	Carbon (Fuse) ⚠
R338	QRZ0052-101	"	"	" ⚠
R339	QRD141J-432SY	4.3 kΩ	"	Carbon
R340	QRD141J-432SY	"	"	"
R341	QRD141J-432SY	"	"	"
R342	QRD141J-432SY	"	"	"
R343	QRD149J-181S	180 Ω	"	" ⚠
R344	QRD149J-181S	"	"	" ⚠
R345	QRD149J-181S	"	"	" ⚠
R346	QRD149J-181S	"	"	" ⚠
R347	QRD141J-182SY	1.8 kΩ	"	"
R348	QRD141J-182SY	"	"	"
R349	QRD149J-151S	150 Ω	"	" ⚠
R350	QRD149J-151S	"	"	" ⚠
R501	QRD149J-361S	360 Ω	"	" ⚠
R502	QRD149J-361S	"	"	" ⚠
R503	QRD141J-622SY	6.2 kΩ	"	"
R504	QRD141J-622SY	"	"	"
R505	QRD141J-393SY	39 kΩ	"	"
R506	QRD141J-393SY	"	"	"
R507	QRD141J-181SY	180 Ω	"	"
R508	QRD141J-181SY	"	"	"
R509	QRD141J-433SY	43 kΩ	"	"
R510	QRD141J-433SY	"	"	"
R511	QRD141J-153SY	15 kΩ	"	"
R512	QRD141J-153SY	"	"	"
R513	QRD141J-132SY	1.3 kΩ	"	"
R514	QRD141J-132SY	"	"	"
R515	QRD141J-202SY	2 kΩ	"	"
R516	QRD141J-202SY	"	"	"

Resistors

Item No.	Part Number	Rating		Description
R517	QRD141J-361SY	360 Ω	1/4 W	Carbon
T518	QRD141J-361SY	"	"	"
R521	QRD141J-223SY	22 kΩ	"	"
R522	QRD141J-223SY	"	"	"
R523	QVZ1709-007	50 kΩ		Variable (Bass)
R524	QVZ1709-008	"		" (Treble)
R611	QRD141J-183SY	18 kΩ	1/4 W	Carbon
R612	QRD141J-183SY	"	"	"
R617	QVZ1713-001	250 kΩ		Variable(Loudness)
R811	QRD141J-273SY	27 kΩ	1/4 W	Carbon
R813	QRD141J-563SY	56 kΩ	"	"
R814	QRG027J-122	1.2 kΩ	2 W	Oxide Metal Film
R817	QRZ0052-150	15 Ω	1/4 W	Carbon (Fuse) ⚠
R818	QRZ0052-150	"	"	" ⚠
R819	QRD149J-471S	470 Ω	1/4 W	Carbon
R820	QRD149J-122S	1.2 kΩ	"	"
R821	QRD129J-271	270 Ω	1/2 W	"

Others

Item No.	Part Number	Rating	Description
J301	EWS013-022		3 Pin Socket Wire Ass'y (To TXX-215-1)
J302	EWS013-023		"
J303	EWS015-014		5 Pin Socket Wire Ass'y (To TXX-215-1)
J601	EWS012-008		2 Pin Socket Wire Ass'y (To TXX-216-2)
J603	EWS016-011		6 Pin Socket Wire Ass'y (To TXX-216-3)
S501	QSP0219-013		Push Switch (Tone)

⚠ : Safety Parts

9. Packing Materials and Part Numbers

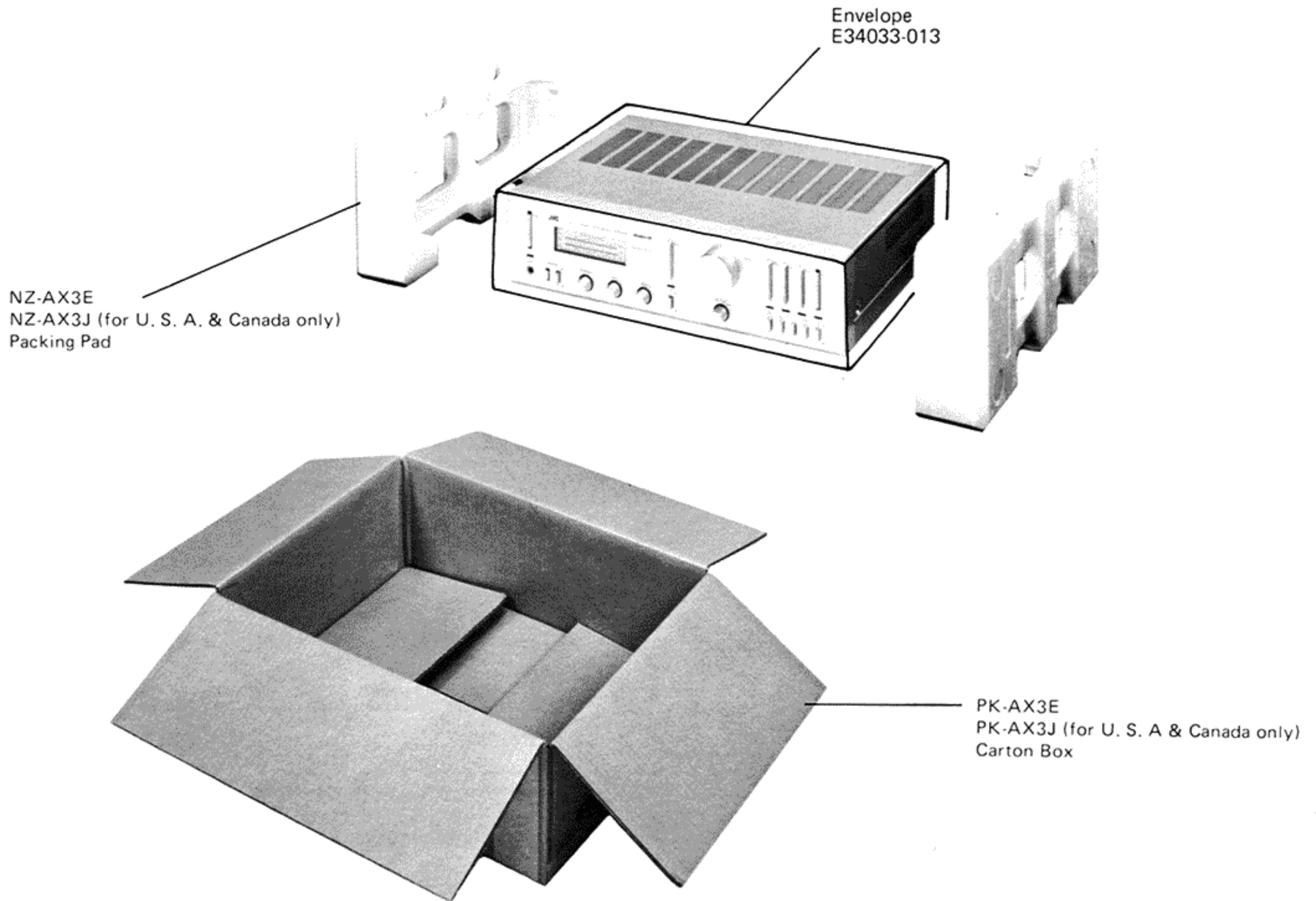

Fig. 22

10. Accessories List

Item No.	Part Number	Description	Q'ty
1	E30580-808A	Instruction Book (for U.K., E30580-808ABS)	1
2	See below	Warranty Card	1
3	E41202-2	Envelope for Instruction Book & Warranty Card	1
4	BT20024B	"Do it Better" (for U.S.A. only)	1
5	BT20023	Service Procedures (for U.S.A. only)	1
6	See page 19	Fuses (for U.S.Military Market & Other Countries)	1
7	E64208-001	Envelope for Fuses (for U.S. Military Market & Other Countries)	1
8	See page 19	Fuse Label	1
9	E64216-002	Caution Tag for Power Cord (for U.S. Military Market)	1

Warranty Card

U.S.A.	Canada	U.K.	Europe	Australia	U.S. Military Market
BT20032B	BT20025C	BT20013C	—	BT20029B	BT20032B

11. A-X3 Schematic Diagram

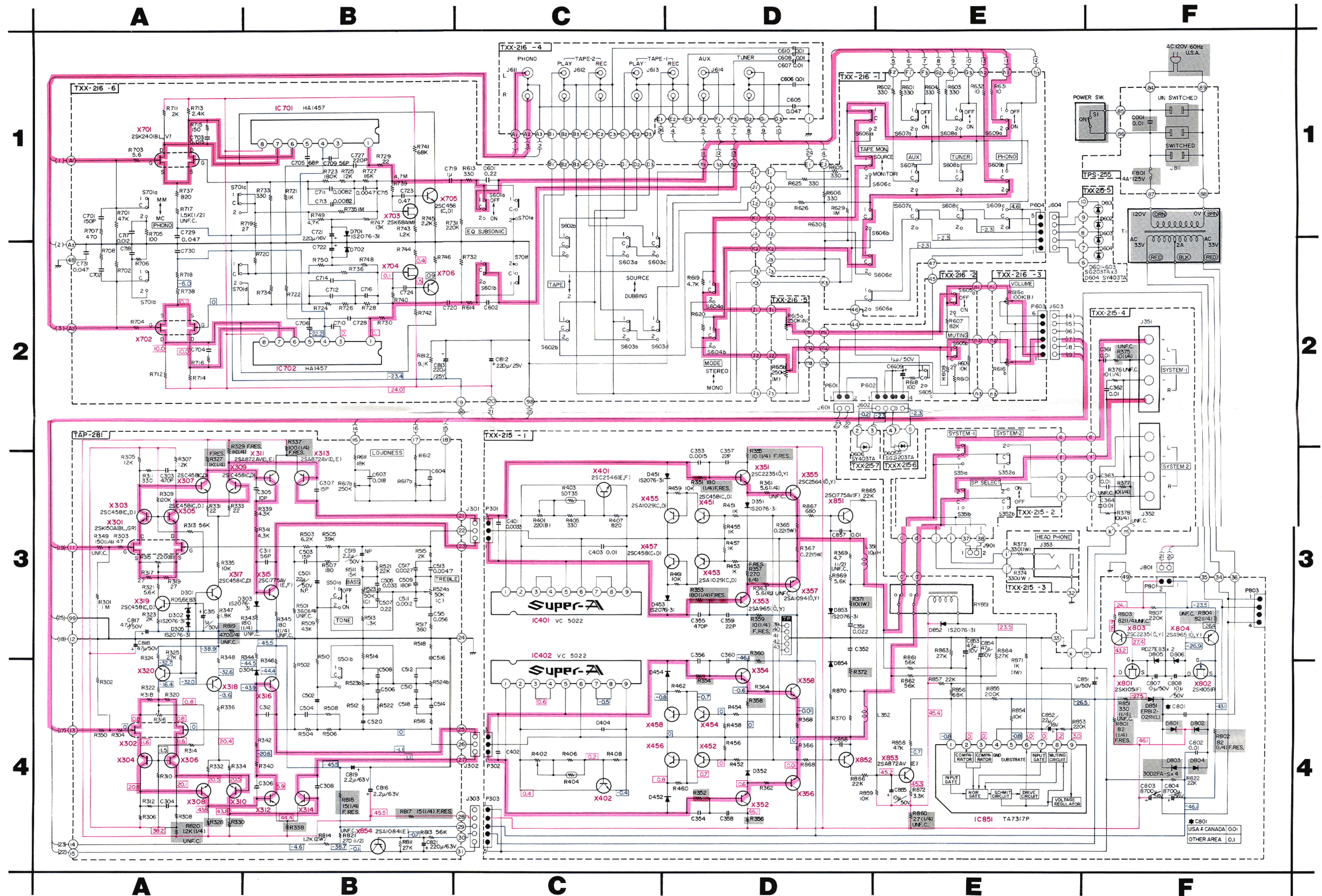

Printed Circuit Board Ass'y Location

P.C. Board Ass'y	Description	Page
TDS-5	LED Power Supply	8
TXX-215	Power Amp., Power Supply and Speakers	8
TXX-216	Equalizer Amp. and Source Selector	11
TPS-234	AC Socket	12
TPS-255	AC Fuse	12
TAP-281	Driver Amp.	14

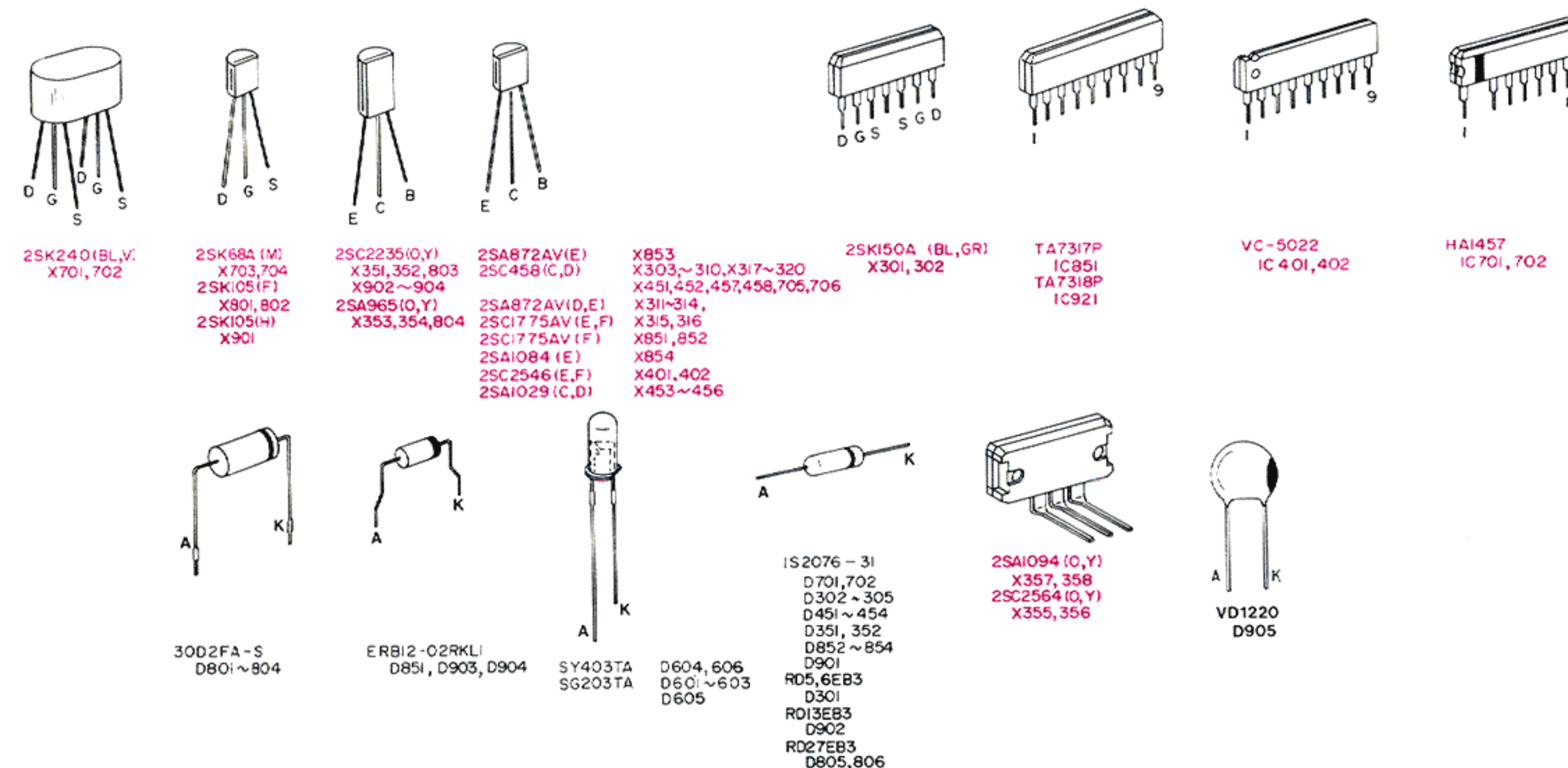

Notes:

1. Voltage values in □ and □ are measured with a tester (impedance 20 kΩ/V) without a signal applied to the unit.
2. Voltage values in □ are positive.
□ indicates positive B power supply.
3. Voltage values in □ are negative.
□ indicates negative B power supply.
4. □ indicates signal path.
5. When replacing the parts in the darkened area and those marked with △, be sure to use the designated parts to ensure safety.
6. This is the standard circuit diagram.
The design and contents are subject to change without notice.

(U),(P) (U) FOR OTHER COUNTRIES
(P) FOR PACEX

(E),(A),(BS) (E) FOR EUROPE : ~220V, 50Hz
(A) FOR AUSTRALIA : ~240V, 50Hz
(BS) FOR U.K. : ~240V, 50Hz

EQ IC IC701, 702 HA1457

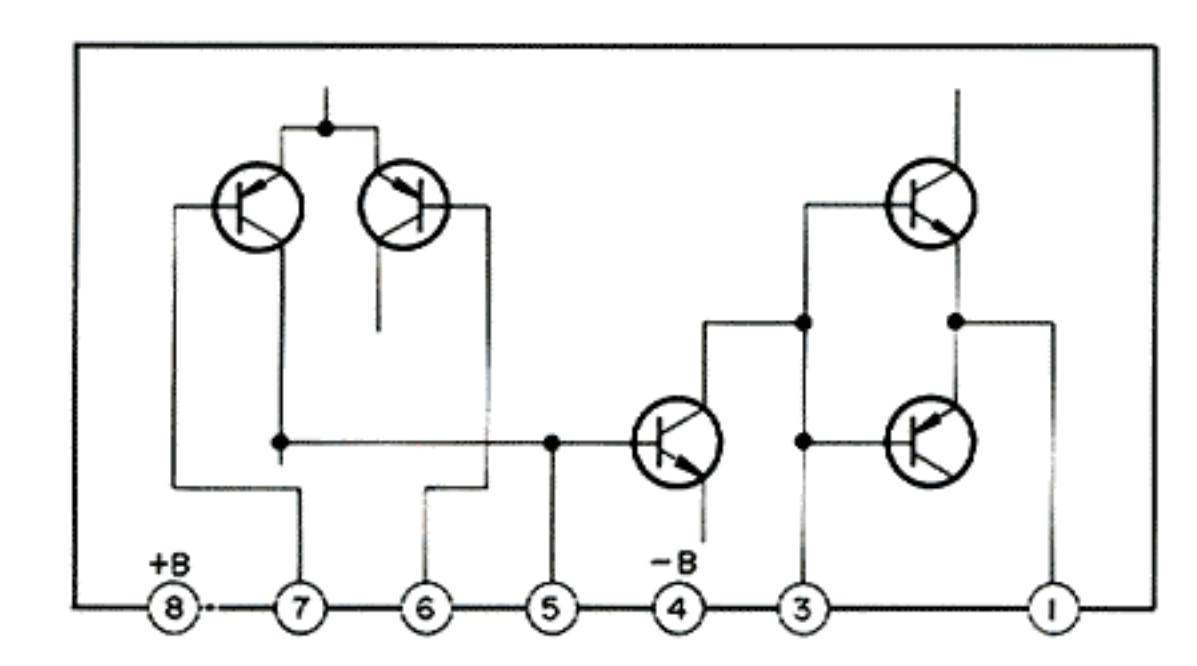
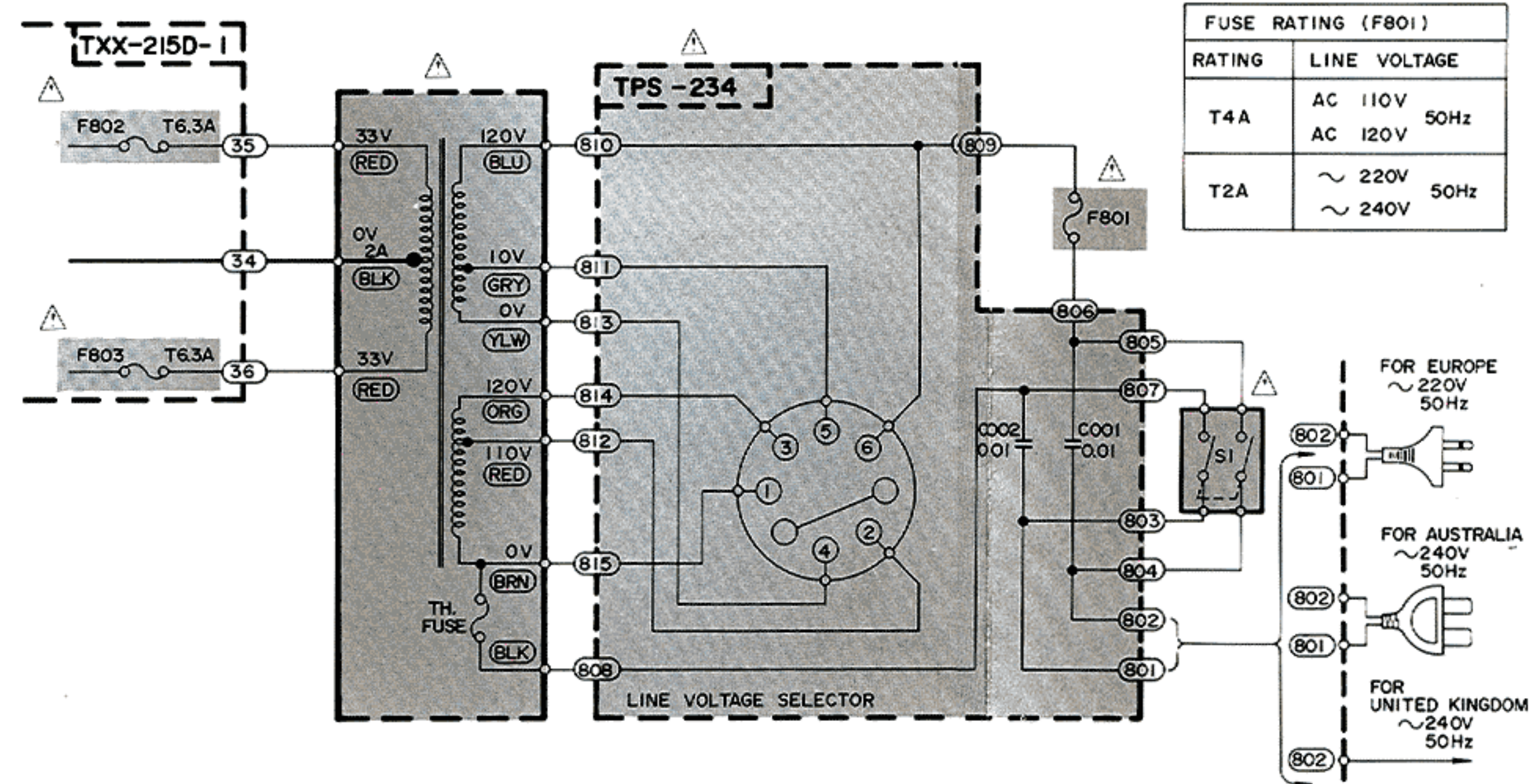
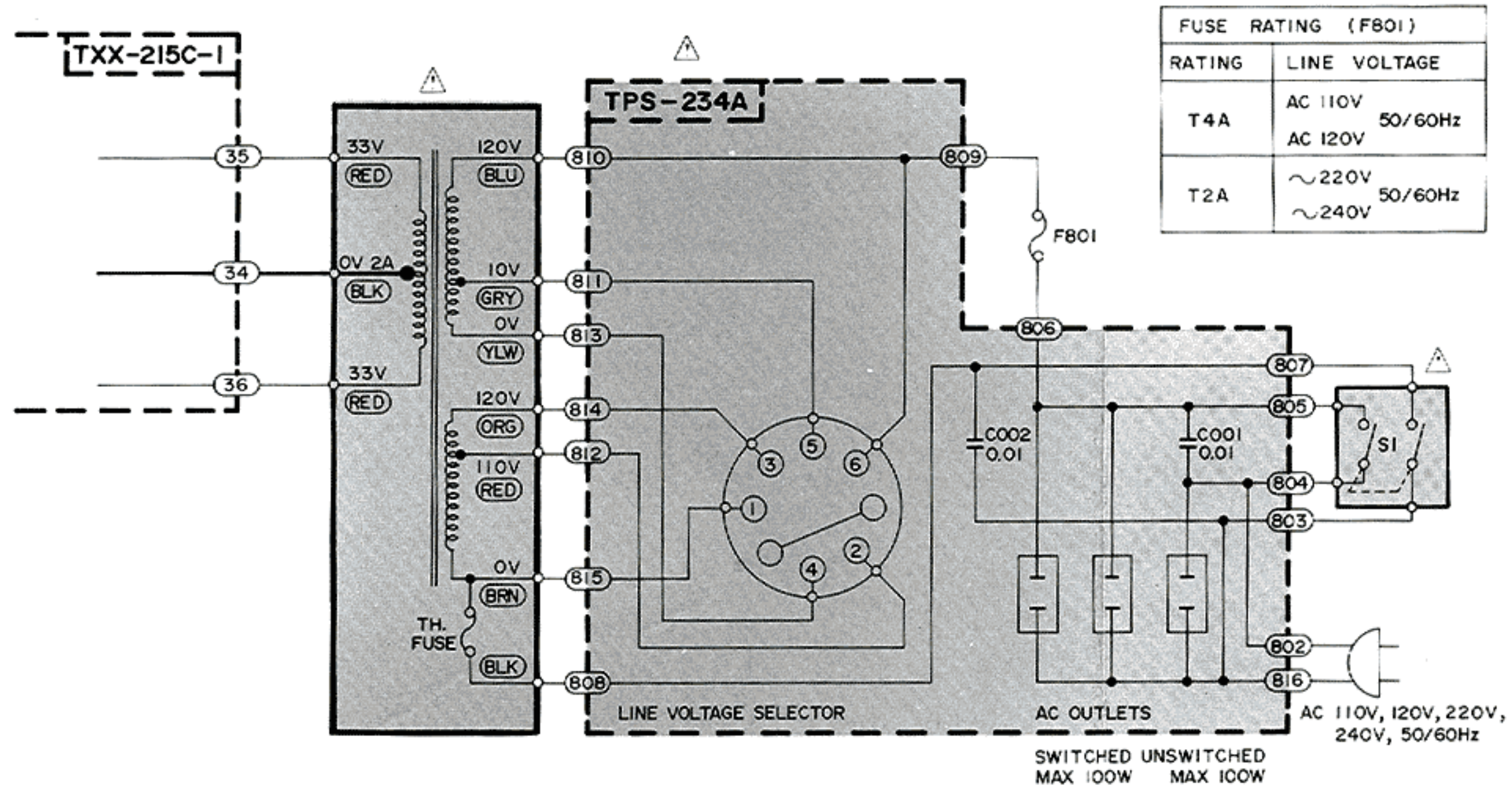

COMPRESSION IC IC921 TA7318P

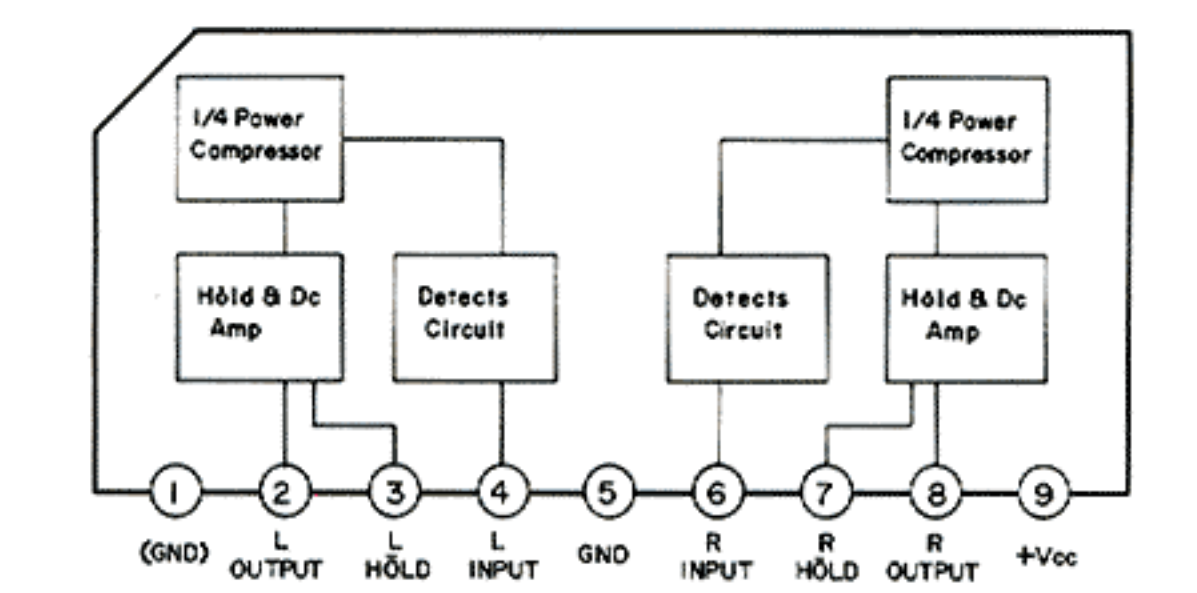

(C) FOR CANADA : AC 120V 60Hz

LED LEVEL METER

LED LEVEL METER UNIT S-5009V

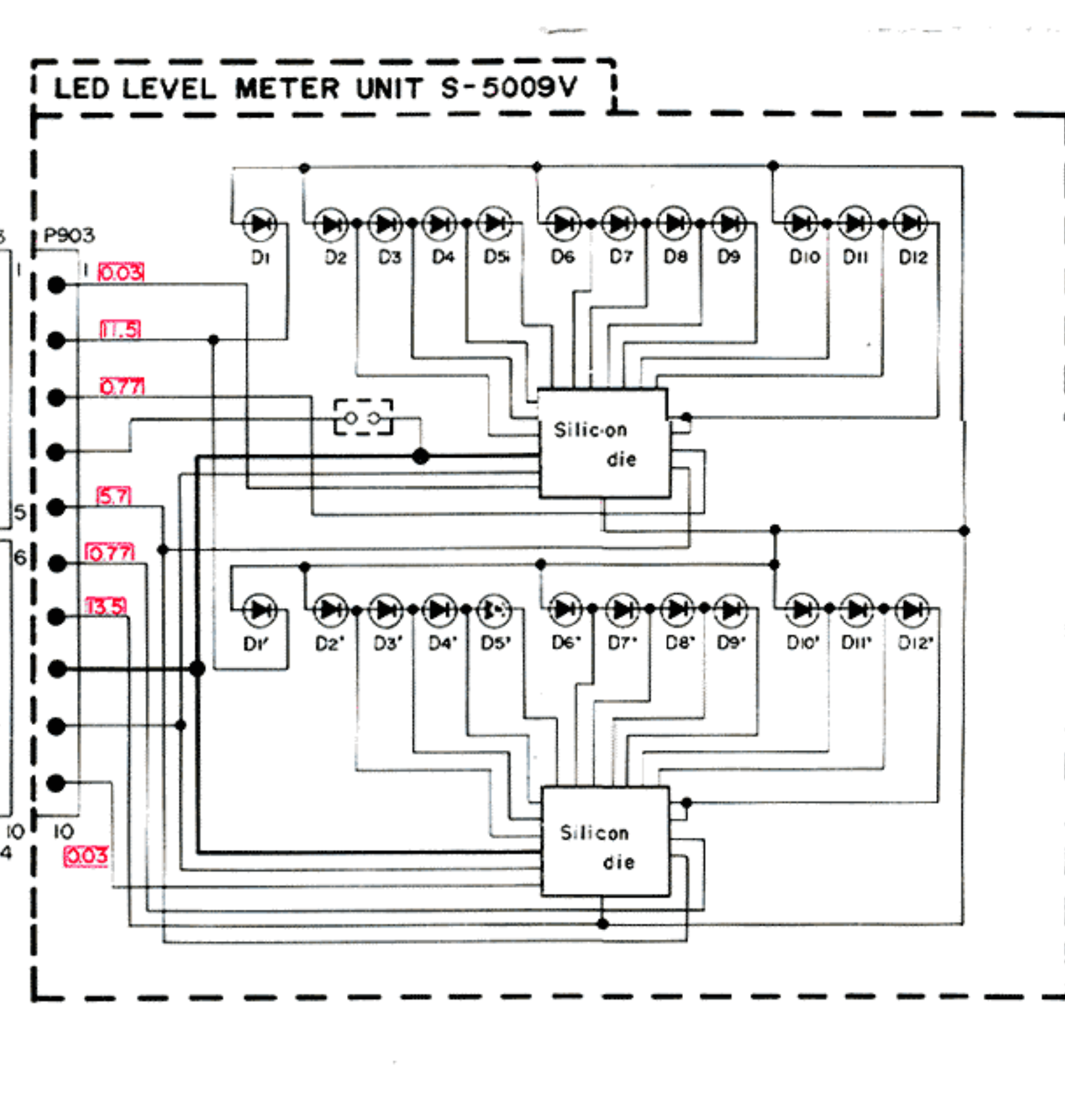
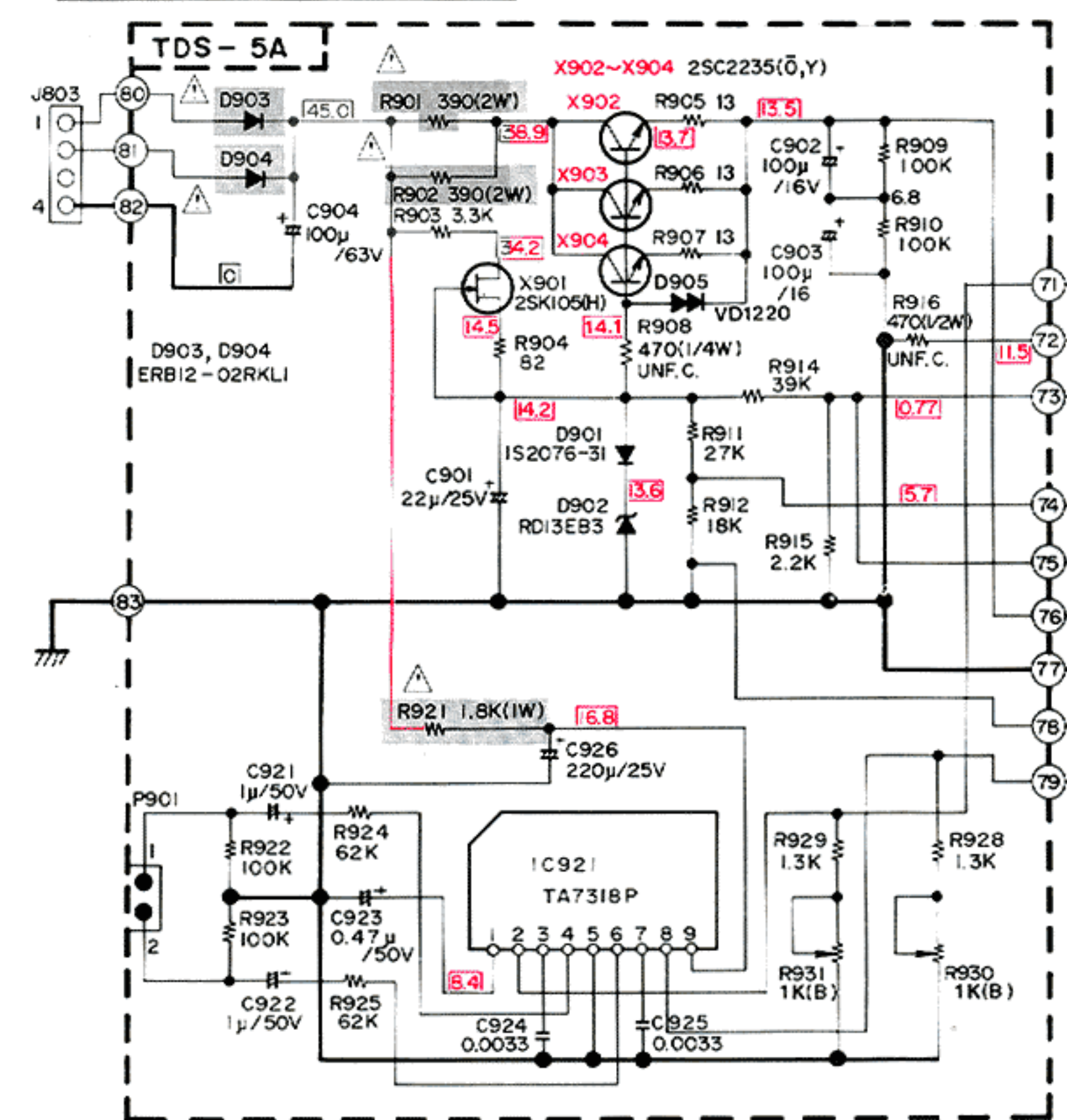
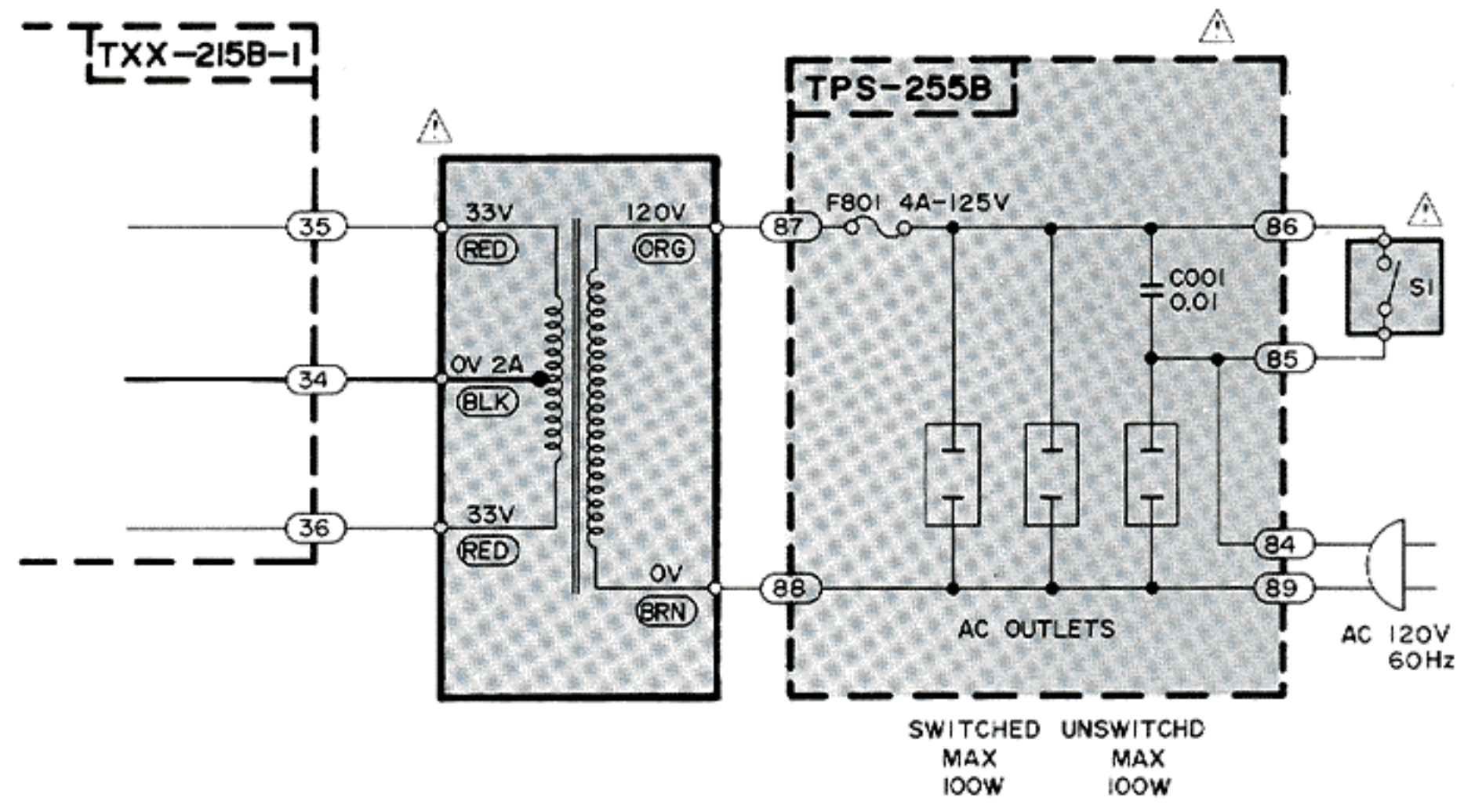

VOLTAGE SELECTOR CONNECTION

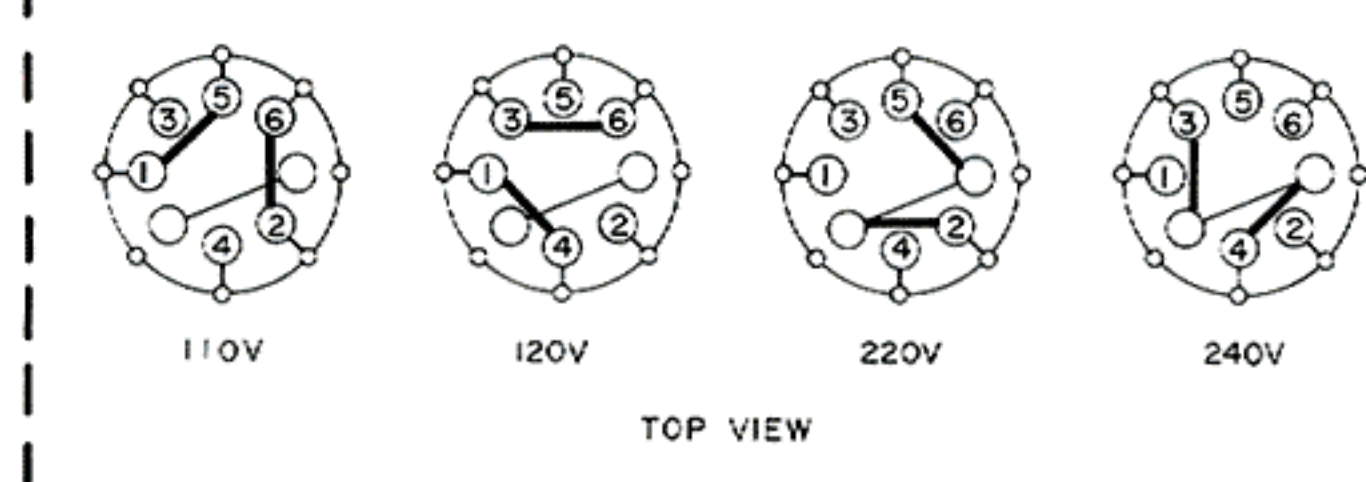

DIN CONNECTOR

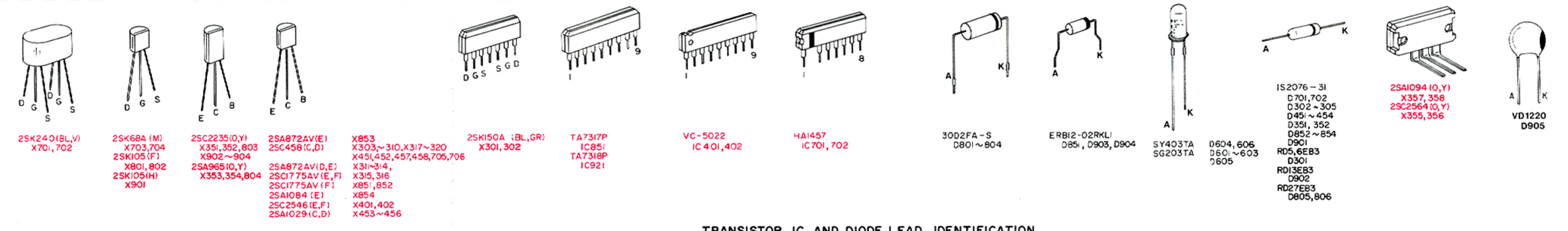
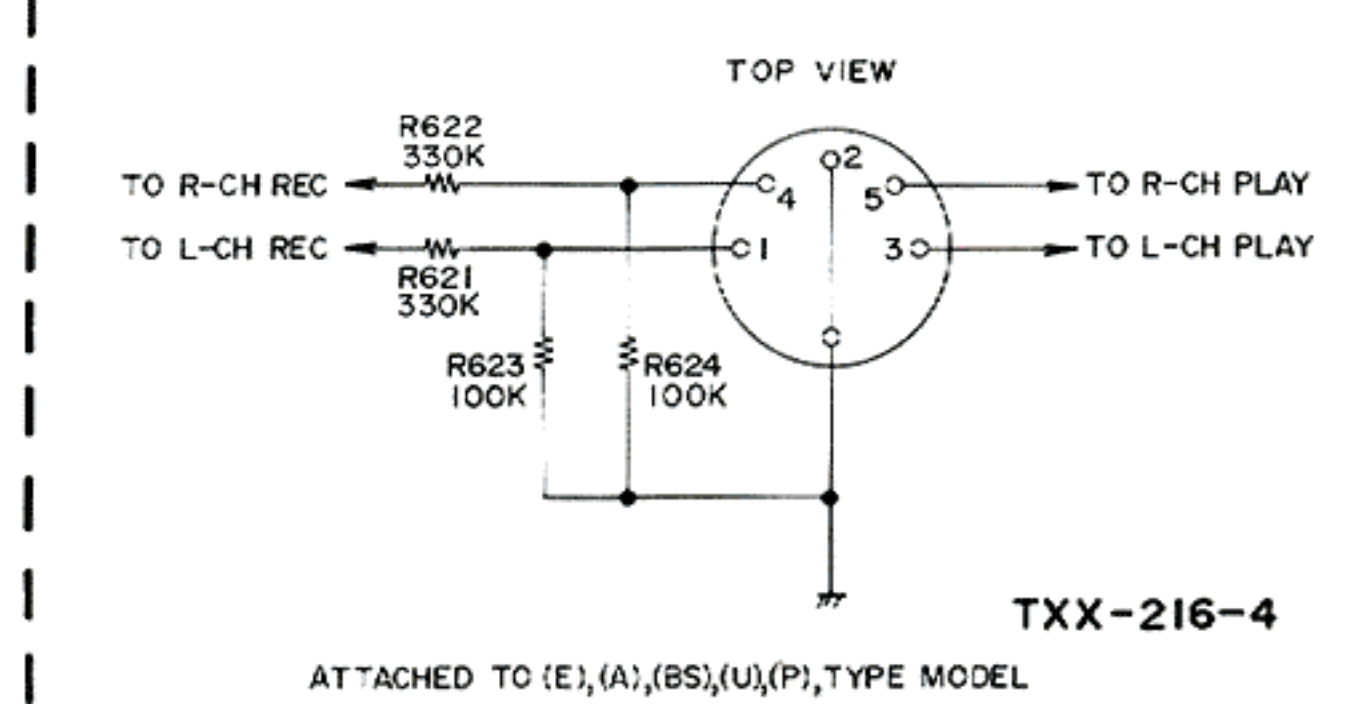













TRANSISTOR, IC AND DIODE LEAD IDENTIFICATION

Printed Circuit Board Ass'y Location

P.C. Board Ass'y	Description	Page
TDS-5	LED Power Supply	8
TXX-215	Power Amp., Power Supply and Speakers	8
TXX-216	Equalizer Amp. and Source Selector	11
TPS-234	AC Socket	12
TPS-255	AC Fuse	12
TAP-281	Driver Amp.	14

- Notes:
- Voltage values in and are measured with a tester (impedance 20 kΩ/V) without a signal applied to the unit.
 - Voltage values in are positive.
— indicates positive B power supply.
 - Voltage values in are negative.
— indicates negative B power supply.
 - indicates signal path.
 - When replacing the parts in the darkened area and those marked with , be sure to use the designated parts to ensure safety.
 - This is the standard circuit diagram.
The design and contents are subject to change without notice.

12. Parts List with Specified Numbers for Designated Areas

Page	Item No.	Description	U.S.A. & Canada	Australia	Europe	U.K.	U.S. Military Market & Other Countries
2, 3		Top Cover (Metal)	E23270-003	E23270-002	E23270-002	E23270-002	E23270-002
2, 3		Cosmetic Board (Left)	ED92933-001	—	—	—	—
		(Right)	ED92933-002	—	—	—	—
2, 3		Screw	E65550-002	E61660-001	E61660-001	E61660-001	E61660-001
3, 4		Side Fitting (Left)	—	E300509-001	E300509-001	E300509-001	E300509-001
3, 4		Side Fitting (Right)	—	E300509-002	E300509-002	E300509-002	E300509-002
3, 13	8-(5)	AC Fuse & Outlets 	TPS-255B	—	—	—	—
13	8-(4)	P.C. Board Ass'y Voltage Selector 	—	TPS-234B	TPS234B	TPS-234CBS	TPS-234A
3		P.C. Board Ass'y Fuse Socket 	—	QMG0301-003	QMG0301-003	QMG0301-003BS	QMG0301-003
3, 13		AC Outlets 	QMC0637-003	—	—	—	QMC0637-003
3, 13		Voltage Selector 	—	QSR0085-001	QSR0085-001	QSR0085-001BS	QSR0085-001
	F801	Fuse (Primary) 	QMF61U1-4R0 (4.0A)	QMF51A2-2R0L (T2A)	QMF51A2-2R0L (T2A)	QMF51A2-2R0LBS (T2A)	QMF51A2-4R0S (T4A) or QMF51A2-2R0L (T2A)
	F802/ F803	Fuse (Secondary) 	—	QMF51A2-6R3S (T6.3A)	QMF51A2-6R3S (T6.3A)	QMF51A2-6R3BS (T6.3A)	—
		Fuse Clip (Secondary) 	—	E48965-002	E48965-002	E48965-002	—
16	8	Fuse Label	—	E67132-T6R3 (for T6A)	E67132-T6R3 (for T6A)	E67132-T6R3 (for T6A)	—
4		Power Transformer 	E03077-46B	E03077-46C	E03077-46C	E03077-46CBS	E03077-46C
4		Power Switch 	QSP1110-301	QSP2111-016	QSP2111-016	QSP2111-016BS	QSP2111-016
3, 4		Power Cord 	QMP1200-200	QMP2560-244	QMP3900-200	QMP9017-008BS	QMP7600-250
3		Strain Relief 	QHS3876-162	QHS3876-162	QHS3876-162	QHS3876-162BS	QHS3876-162
3, 4		Front Panel Ass'y	EFP-AX3EJ	EFP-AX3EE	EFP-AX3EE	EFP-AX3EE	EFP-AX3EE
3		Rear Panel	E23268-001	E23268-002	E23268-002	E23268-002	E23268-002
3		Masking Plate	—	E65494-002	E65494-002	E65494-002	—
4, 8	8-(2)	Power Amp. & Power Supply	TXX-215B	TXX-215D	TXX-215D	TXX-215D	TXX-215C
4, 11	8-(3)	P.C. Board Ass'y Equalizer & Select Switch	TXX-216B	TXX-216C	TXX-216C	TXX-216C	TXX-216C
10	R371/ R372	P.C. Board Ass'y Resistor (Oxide Metal Film) 	QRX017J-100S	QRZ0049-100 (Fuse Type)	QRZ0049-100 (Fuse Type)	QRZ0049-100 (Fuse Type)	QRX017J-100S
10	R375/ R376/ R377/ R378	Resistor (Carbon)	QRD149J-100S	QRZ0049-100 (Fuse Type)	QRZ0049-100 (Fuse Type)	QRZ0049-100 (Fuse Type)	QRD149J-100S

NOTE:  SAFETY PARTS

Power Specifications

Area	Line Voltage & Frequency	Power Consumption
U.S.A.	AC 120 V, 60 Hz	235 W
CANADA	AC 120 V, 60 Hz	300 VA
EUROPE, U.K. & AUSTRALIA	AC 110/120/220/240 V ~ Selectable, 50 Hz	460W
OTHER AREAS	AC 110/120/220/240 V ~ Selectable, 50/60 Hz	460 W

JVC

VICTOR COMPANY OF JAPAN, LIMITED, TOKYO, JAPAN

 Printed in Japan
9012-V